

# A low-noise high-speed diode laser current controller

K. G. Libbrecht

*Norman Bridge Laboratory of Physics, 12-33 California Institute of Technology, Pasadena, California 91125*

J. L. Hall<sup>a)</sup>

*Joint Institute for Laboratory Astrophysics of the National Institute of Standards and Technology, Boulder, Colorado 80309-0440*

(Received 15 March 1993; accepted for publication 26 March 1993)

We describe a new diode laser current controller which features low current noise, excellent dc stability, and the capacity for high-speed modulation. While it is simple and inexpensive to construct, the controller compares favorably with the best presently available commercial diode laser current controllers.

## I. INTRODUCTION

Semiconductor diode lasers have recently become useful tools in many areas of scientific research as inexpensive sources of tunable monochromatic laser light.<sup>1</sup> Since the laser frequency and output power depend on both the diode junction temperature and injection current, stable laser operation requires that these quantities be precisely regulated. In addition, to lock the laser frequency at some fixed value (e.g., near an atomic resonance line), or to add frequency sidebands to the laser output, one desires the ability to rapidly modulate the injection current. For example, a free-running diode laser experiences a frequency change with injection current of typically 3 MHz/ $\mu$ A,<sup>1</sup> while with feedback from an external grating this may drop to  $\sim$ 0.3

MHz/ $\mu$ A. Thus to regulate the frequency of a free-running laser to a small fraction for its linewidth, a current stability of 1  $\mu$ A is desired; for a laser with an external grating, to realize a linewidth of 100 kHz one requires a current noise below  $\sim$ 300 nA rms.

To achieve the necessary low noise and stability, a number of commercial current and temperature controllers are available, and circuits designed for diode lasers have appeared in the literature.<sup>1,2</sup> As to temperature controllers, we have achieved satisfactory performance with the published systems,<sup>1,2</sup> and we find (as with Ref. 2) that the performance limit is usually related to the physical separation between the sensing and temperature control points. However, with regard to laser current control circuits, we

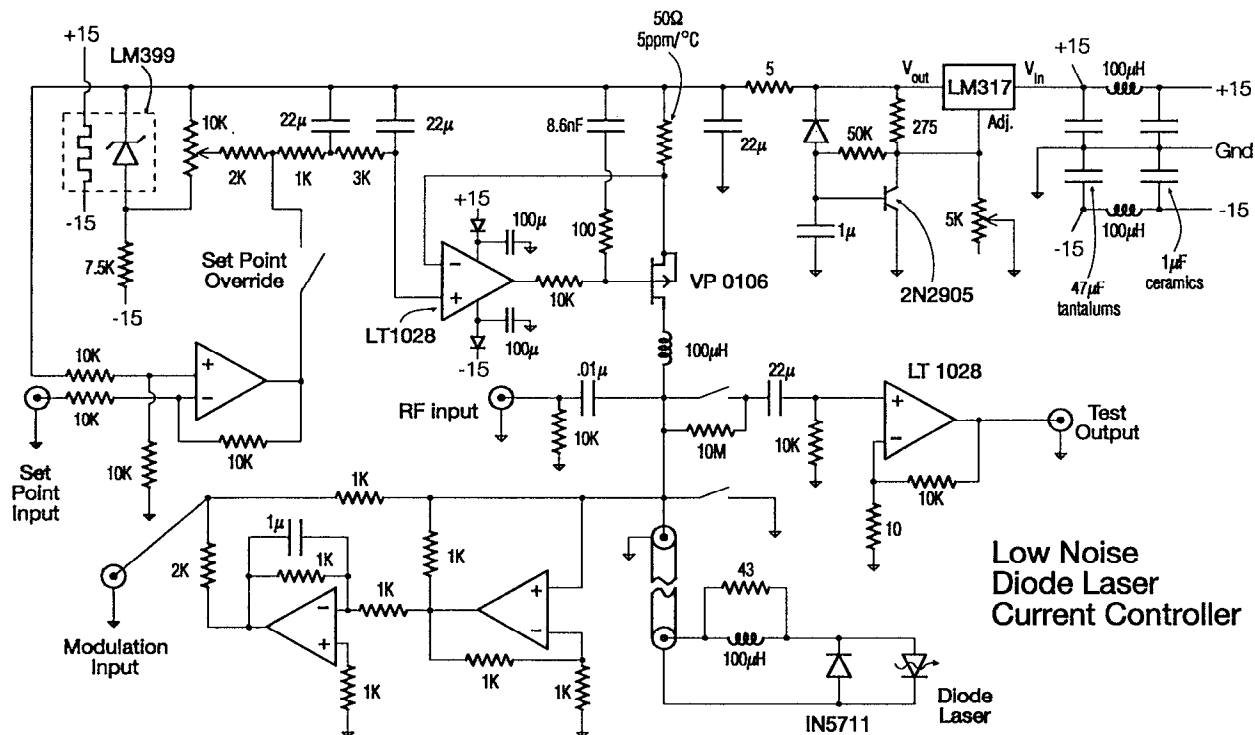

FIG. 1. Diode laser current controller circuit schematic. The circuit will supply up to 200 mA, with a stability of  $\sim$ 1  $\mu$ A/ $^{\circ}$ C and a current noise of  $<$ 50-nA rms in a 1-MHz bandwidth. Unspecified op-amps are OP-27.

<sup>a)</sup>Staff Member, National Institute of Standards and Technology.

found room for improvement. In this article we describe a new diode laser current controller which combines high stability and low current noise, yet is easily modulated. Our controller is a significant improvement over previously published circuits, and despite its simplicity it compares favorably with the best presently available commercial current controllers.

## II. CIRCUIT DESCRIPTION

Figure 1 shows the current controller schematic.<sup>3</sup> The LM317 was used both to bring the supply voltage down from 15 V, and to provide a slow turn-on and current limit to the diode laser, set by the 5-k $\Omega$  trimpot. The LM399-based voltage reference was heavily filtered to reduce noise, and the RC attenuation network in the LT 1028 circuit provides stable operation and low noise.

As with previous circuits, our controller uses a sense resistor in series with the load to produce a voltage which is compared with a stable reference voltage. To produce good dc stability, stable components were selected: the LM399 has a temperature coefficient of 0.5 ppm/ $^{\circ}$ C; the 50- $\Omega$  Vishay sense resistor (VHP-3) has a temperature coefficient of 5 ppm/ $^{\circ}$ C; and the LT1028 features an input offset temperature drift of 0.25  $\mu$ V/ $^{\circ}$ C. The wire-wound current adjusting potentiometer has a temperature coefficient of 20 ppm/ $^{\circ}$ C, but much of this is expected to cancel since it is used differentially. This potentiometer also adds

a thermocouple potential owing to the different materials used in the resistor wire and the slider tap, which drifts at roughly 40  $\mu$ V/ $^{\circ}$ C.<sup>4</sup> Assuming an operating current of 100 mA, the current temperature drift is then expected to be  $\sim$ 1  $\mu$ A/ $^{\circ}$ C, the dominant contributors being the potentiometer and the sense resistor. Using a temperature-controlled load resistor and a precision voltmeter, the current drift under typical laboratory conditions was measured to be  $<$ 0.25  $\mu$ A in 3 h. The resolution in the current set point is limited by the potentiometer, and could be enhanced by using coarse and fine adjustments or digital step switches. We normally servo the current to lock the laser to a fixed reference, and so have found the resolution from a single potentiometer is usually adequate. Also note that the temperature coefficient of copper is roughly 1000 times that of the Vishay sense resistor. Thus even the small resistance of the wires connecting the resistor (which in our case is chassis mounted for temperature stability) could impair the circuit's performance. For maximum dc current stability this resistor should be wired in a four-terminal configuration.

The LT1028 also features a low voltage noise, typically 0.85 nV/ $\sqrt{\text{Hz}}$ , optimized for low input impedance.<sup>5</sup> Combining the amplifier noise with the thermal noise of the 50- $\Omega$  resistor gives an expected current noise of  $\sim$ 25 pA/ $\sqrt{\text{Hz}}$ . Figure 2 shows measurements of the noise performance over various frequency ranges. For  $\nu <$  1 kHz [Fig.

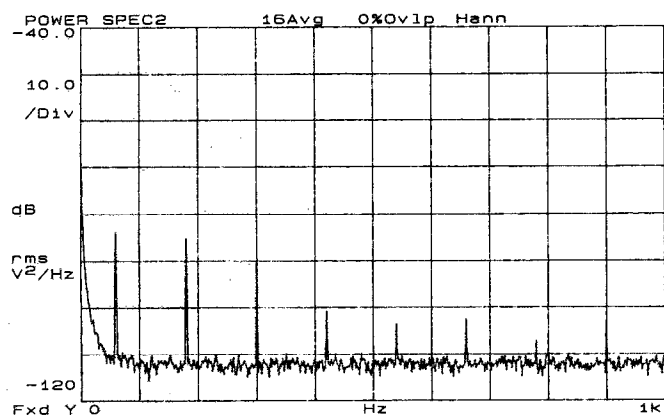

(a)

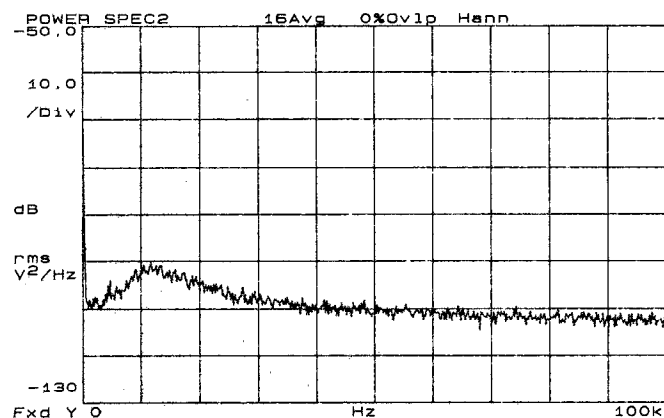

(b)

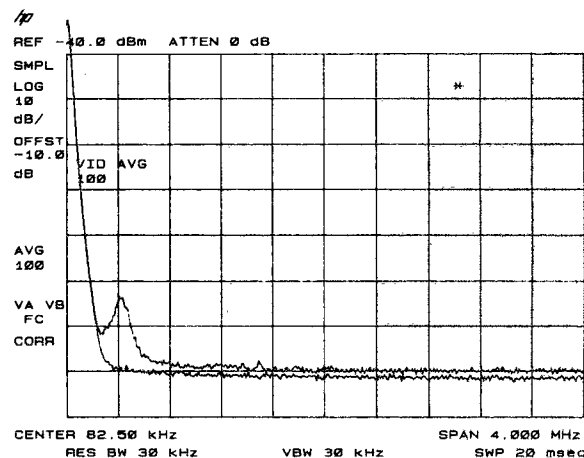

(c)

FIG. 2. Noise measurements of the current controller in various frequency ranges, using a 50- $\Omega$  load resistor and an operating current of 100 mA. (a) Low-frequency noise performance of the current controller, using the test circuit shown in Fig. 1. (b) Same as (a), but to higher frequencies. (c) High-frequency noise performance. Here voltage across the 50- $\Omega$  load resistor was amplified 20 dB (amplifier input impedance also 50  $\Omega$ ), and measured with a spectrum analyzer. The upper trace is the current controller noise, and the lower trace is the residual amplifier and spectrum analyzer noise. The 400-kHz bump is a feature intrinsic to the LT1028 op-amp, and is a dominant contributor to the overall current noise.

2(a)], the measured noise is about  $40 \text{ pA}/\sqrt{\text{Hz}}$  (after subtracting the noise added by the test circuit), in rough agreement with expectations. The noise at 60 Hz and harmonics is significant, but kept under control by using a power supply outside of the current controller chassis. With this one can avoid using batteries to drive the controller. Axial lead, hermetically sealed tantalum capacitors were used for the critical low-pass filter locations, since other capacitors—particularly miniature high-value, low voltage ceramic capacitors—were found to contribute significant low-frequency noise. At intermediate frequencies [Fig. 2(b)], an increase in the noise is seen around 12 kHz, and at higher frequencies [Fig. 2(c)] the noise is flat except for another bump near 400 kHz. The 400 kHz bump was found to be a feature intrinsic to the LT1028, as determined by examining the noise of this op-amp configured as a simple amplifier. Adding the various contributions to the noise—13-nA rms from the  $100 \text{ Hz} < \nu < 100 \text{ kHz}$  baseline, 16-nA rms from the 12-kHz bump, 20-nA rms from the  $100 \text{ kHz} < \nu < 1 \text{ MHz}$  baseline, and 35-nA rms from the 400-kHz bump—we find a total noise of  $\sim 45\text{-nA}$  rms noise in a 1-MHz bandwidth.

To modulate the diode current, several options were included, as shown in Fig. 1. For large current adjustments, an external voltage overrides the LM399-based reference voltage. For low-level current modulation, from dc to  $\sim 10 \text{ MHz}$ , an external input voltage is used to draw current away from the diode without changing the current passing through the sense resistor. For convenience we have included a dual compensating circuit for this modulation channel, so that grounding the modulation input point does not change the diode laser's operating point. In operation, the diode voltage  $U$  is amplified  $2\times$ , before the unity-gain inverter which drives the 2-K resistor to the modulation input port. The current through this resistor,  $-2U/2 \text{ K}$ , just cancels the current  $U/1 \text{ K}$  coming through the 1-K direct modulation resistor. Thus the modulation input port is nominally at zero potential, independent of the diode's potential. This is desirable when this

modulation/correction signal is obtained from a voltage-sensitive device, such as a balanced mixer used as a phase detector. To replace the current drawn from the laser diode current controller output to this virtual ground, another 1-K resistor supplies a replacement current of  $(2U-U)/1 \text{ K}$  from the output of the plus 2 gain stage. The noise contribution of these added amplifiers is negligible. One could more easily approximate this virtual ground aspect by using a low impedance, for example  $50 \Omega$ , to terminate the modulation input port, at the expense of changing the diode set current when the laser's band-gap voltage is changed thermally.

An ac-coupled input is also included for adding rf sidebands to the laser output. The diode's low ac impedance is increased by the 43- $\Omega$  resistor to give a 50- $\Omega$  match for the rf input, while the parallel 100- $\mu\text{H}$  rf choke insures a negligible dc drop.

## ACKNOWLEDGMENTS

We enthusiastically thank Professor H. J. Kimble for his generous hospitality and interest in this work. JLH would also like to thank the Sherman Fairchild Distinguished Visiting Scholars Program for the opportunity to participate in this work at Caltech. KGL is supported in part by an AT&T Special Purpose Grant, and by a National Science Foundation Presidential Young Investigator Award. JLH is supported in part at JILA by the National Institute of Standards under its program of precision metrology research for future standards applications, and by the Office of Naval Research, the Office of Air Force Research, and the National Science Foundation.

<sup>1</sup>C. E. Wieman and L. Hollberg, *Rev. Sci. Instrum.* **62**, 1 (1991).

<sup>2</sup>C. C. Bradley, J. Chen, and R. G. Hulet, *Rev. Sci. Instrum.* **61**, 2097 (1990).

<sup>3</sup>In this discussion, designation of components by their commercial names is purely for technical communication purposes, and does not imply that they are necessarily the best available.

<sup>4</sup>J. Magyar, private communication, NIST, Boulder, 1992.

<sup>5</sup>P. Horowitz, and W. Hill, *The Art of Electronics*, 2nd ed. (Cambridge University Press, Cambridge, 1989).