

Heterodyne Instrumentation at the CSO

Jacob W. Kooi^a, P.L. Schaffer^a, Bruce Bumble^b, Rick LeDuc^b, and T.G. Phillips^a

^aCalifornia Institute of Technology, 320-47, Pasadena CA 91125

^bCenter for Space Microelectronics technology, Jet Propulsion Laboratory, Pasadena CA 91108

ABSTRACT

The Caltech Submillimeter observatory (CSO) is one of the World's premier submillimeter telescopes. It consists of a 10.4 meter diameter Leighton radio dish situated in a compact dome near the summit of Mauna Kea, Hawaii. The telescope has been operating under a contract from the National Science Foundation on a regular basis since 1988. For the first time heterodyne Superconducting-Insulating-Superconducting (SIS) receivers with a 1 GHz intermediate frequency (IF) are available for the entire 180 - 950 GHz Submillimeter band. To enhance the extra-galactic capabilities of the observatory and to allow interferometry with the upcoming Submillimeter Array (SMA) project, we are actively working towards upgrading all heterodyne instruments with a 3 GHz IF bandwidth. Concurrent to the planned IF upgrade, we are constructing a dual polarization beam switching 345 GHz extra-galactic receiver, also with a 3 GHz IF bandwidth. Ideally, this instrument will give the CSO a factor of 8 improvement in integration time over the current 345 GHz receiver, and will be ideally suited for the study of highly red-shifted extra-galactic sources.

Keywords: SIS junctions, Heterodyne Instrumentation, Intermediate Frequency, Sub-millimeter Astronomy.

1. INTRODUCTION

The quasi-particle Superconducting-Insulator-Superconducting (SIS) tunnel mixer is known to have great potential for producing heterodyne receivers with quantum noise limited performance¹ for high resolution spectroscopy. It is not too surprising therefore that the SIS mixer has become the receiver of choice for submillimeter spectroscopic radio astronomy. There are two basic types of SIS receivers, waveguide and quasi-optical. Currently all five SIS receivers installed at the CSO are of the double tuned waveguide type and have seen several evolutionary changes over the last 10 years. Ellison *et al.* first installed a lead alloy based 230 GHz full height waveguide SIS receiver² at the Observatory in 1986. This receiver was state of the art at the time and had a 500 MHz IF bandwidth with a 114K DSB receiver noise temperature. A second 345 GHz Pb-alloy based receiver³ (217K DSB) soon followed in 1988. Both mixers utilized a full-height waveguide with E-plane and Backshort tuners and corrugated scalar feedhorn. The mixers were constructed by Custom Microwave⁴. The Pb-alloy SIS tunnel devices employed in the mixer blocks did not have an integrated RF matching network to tune out the large parasitic capacitance of the SIS junction. This necessitated the use of two waveguide tuners to help match the detector impedance to the waveguide over much of the waveguide band, similar to concepts used in earlier Schottky technology.

An alternative to the waveguide tuner concept is a design which employs lithographic tuning, in the form of an inductive microstrip stub, actually on the detector chip. The idea of tuning out the SIS parasitic junction capacitance has been around for quite some time⁵⁻⁹, but has become only practical with recent advances in niobium processing techniques. The concept of tuning out the junction capacitance on chip is clearly superior, than solely relying on waveguide tuners, since it puts the reactance's where they should be, as close as possible to the detector element. Excellent performance such as large instantaneous bandwidth and near quantum limited performance have been achieved over the last few years by many authors¹⁰⁻²¹. At the CSO we have opted for a combination of on chip tuned devices (Fig. 2,5,7) with double tuned waveguide mixers (Fig. 1). This combination has proved very successful in that continuous DSB coverage is currently available for all of the submillimeter frequency atmospheric windows (180-950 GHz) with near quantum limited mixer noise performance.

Another recent development is the quasi-optical SIS receiver. The idea here is to generate an integrated SIS junction and lithographic antenna structure, which replaces the entire feedhorn, waveguide/tuners and SIS junction chip combination.

Different quasi-optical antenna structures have been proposed over the years²²⁻²⁵, with the most successful one being the twin slot low impedance dipole antenna by Zmuidzinas²⁶⁻²⁹ *et al.* The double slot quasi-optical mixer has been successfully demonstrated on the Kuiper Airborne Observatory (KAO) and at the CSO on many occasions, but is at the present time not

integrated as one of the facility instruments. The technology is however ideally suited for THz frequencies and imaging arrays.

2. CSO HETERODYNE RECEIVER INSTRUMENTATION

2.1 Mixer block construction

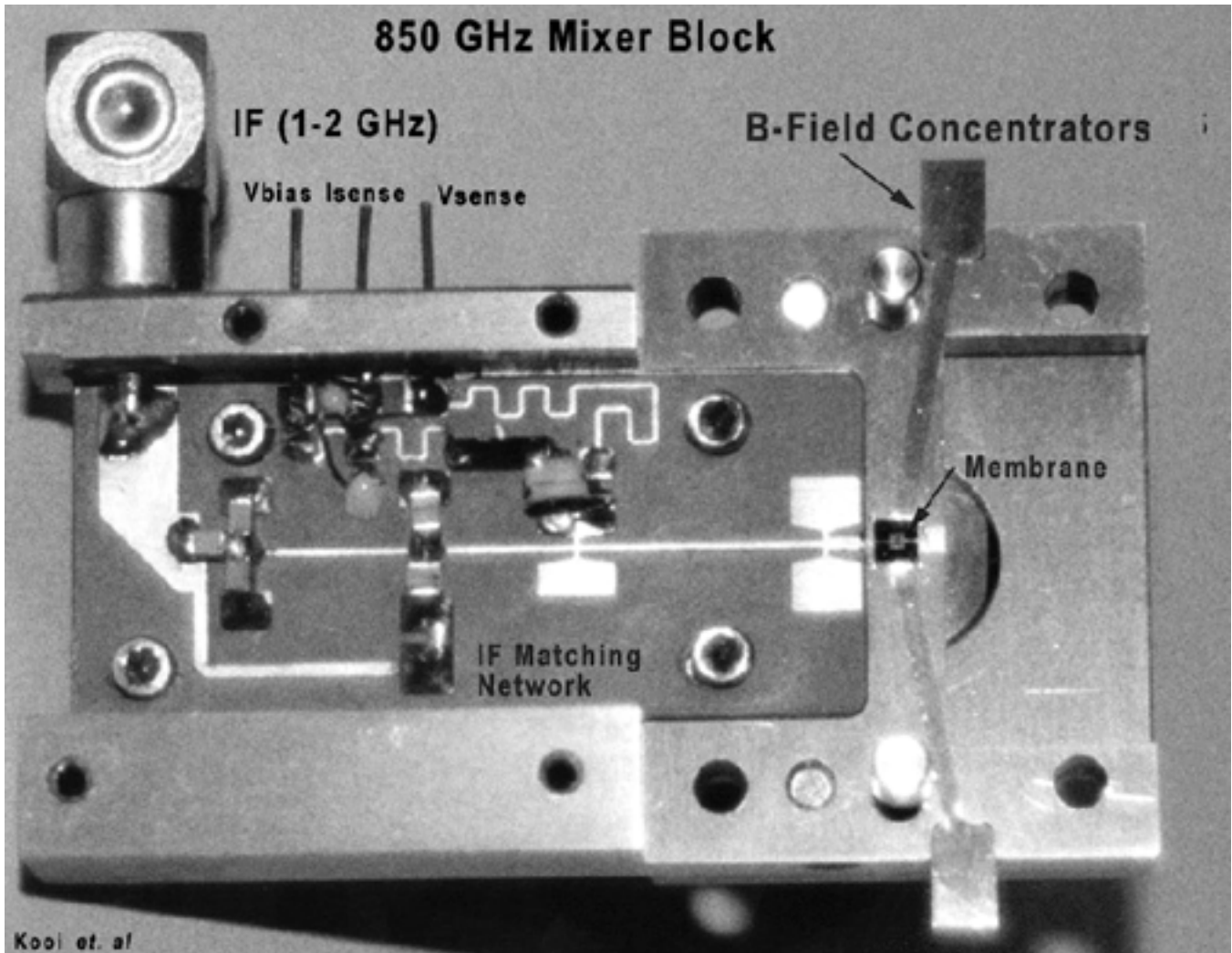

Figure 1. 850 GHz Mixer block with a Si_3N_4 membrane SIS tunnel Junction and 1-2 GHz IF matching network.

As discussed in the introduction, the basic mixer blocks at the CSO are based on earlier fullheight waveguide design by Ellison^{2,3} *et al*, magnetic field concentrators and an integrated IF matching network were later added by Walker³⁰ and Kooi¹⁰ *et al*. In the later designs, the front section of the mixer blocks are constructed on one mandrel³¹ in order to reduce the number of waveguide discontinuities and minimize ohmic loss. The mandrel is composed of a corrugated feedhorn, circular-to-rectangular waveguide transformer and E-plane tuner. The junction block and non-contacting backshort tuner make up the back section of the mixer block (Fig. 1). In the design the E-plane tuner is situated $1/2 \lambda_g$ in front of the junction. The non-contacting tuners consists of three beryllium-copper concentric circular sections that extend from a rectangular shaft which is carefully fitted inside the waveguide³². On the IF side the junction is either wire bonded or silver-painted to the 1-2 GHz IF matching network. The matching network is designed to transform the 160Ω junction IF impedance to 50Ω and provide a short circuit to out-of-band signals up to 22 GHz. The output of the mixer blocks are directly connected to cryogenic cooled

1-2 GHz balanced HEMT amplifiers (Fig. 9), based on work by Padin³³ *et al.* Reflections caused by the impedance mismatch between the matching network and the low noise amplifier are for the most part absorbed by the amplifier's Lange coupler (S11<-15dB). The corrugated feedhorn launches a F/2.5 beam which is coupled to the telescope beam via a cold lens or elliptical mirror. In all instances great care has been taken to center the junction in the center of the waveguide, where the E-field is the strongest.

2.2 SIS tunnel junction design below the bandgap frequency of Niobium

In the past, high quality waveguide tuners have been relied upon to tune out the large geometric junction capacitance of the few Angstrom thick AlO_x barrier sandwiched between two superconductors, in our case niobium. This however places a severe demand on the quality of the waveguide tuners and results in a relatively small frequency range over which an adequate match to the junction can be achieved (small instantaneous bandwidth). To improve the junction RF match to the waveguide embedding impedance and increase the instantaneous bandwidth of the mixer a variety of tuning stubs have been introduced over the years. One of the most successful RF matching networks¹¹⁻¹⁸ is the 'end-loaded stub', and as such will be briefly elaborated on in this chapter.

To keep the $\omega R_j C_j$ product of the junction as small as possible, allow good coupling to the IF impedance (160Ω), and maintain high quality devices we decided to use Nb/ AlO_x /Nb SIS tunnel junctions with a $R_n A$ product of $25 \Omega\text{-cm}^2$. Secondly, in order to achieve a good match over the desired frequency band it is imperative that a probe impedance $Z_p(\omega)$ is selected that can easily be tuned to over the entire frequency range. In house as well as published³⁴⁻³⁶ full height waveguide scale mixer model measurements indicate that the embedding impedance of a bowtie probe with a 45 degree flare angle, centered in the waveguide, is on the order of $35\text{-}40 \Omega$ and slightly inductive. By adjusting the non-contacting tuners we can keep $Z_p(\omega)$ approximately constant over the entire frequency range, or tune to a conjugate match. An alternative design is to use an half height waveguide with a suspended stripline design and fixed backshort tuner. This technique has been very applied successfully by the Submillimeter Array (SMA) receiver group¹⁴⁻¹⁶. Fixing the backshort tuner will reduce to some extent the usable bandwidth of the mixer, but has the advantage of greatly simplifying the required hardware.

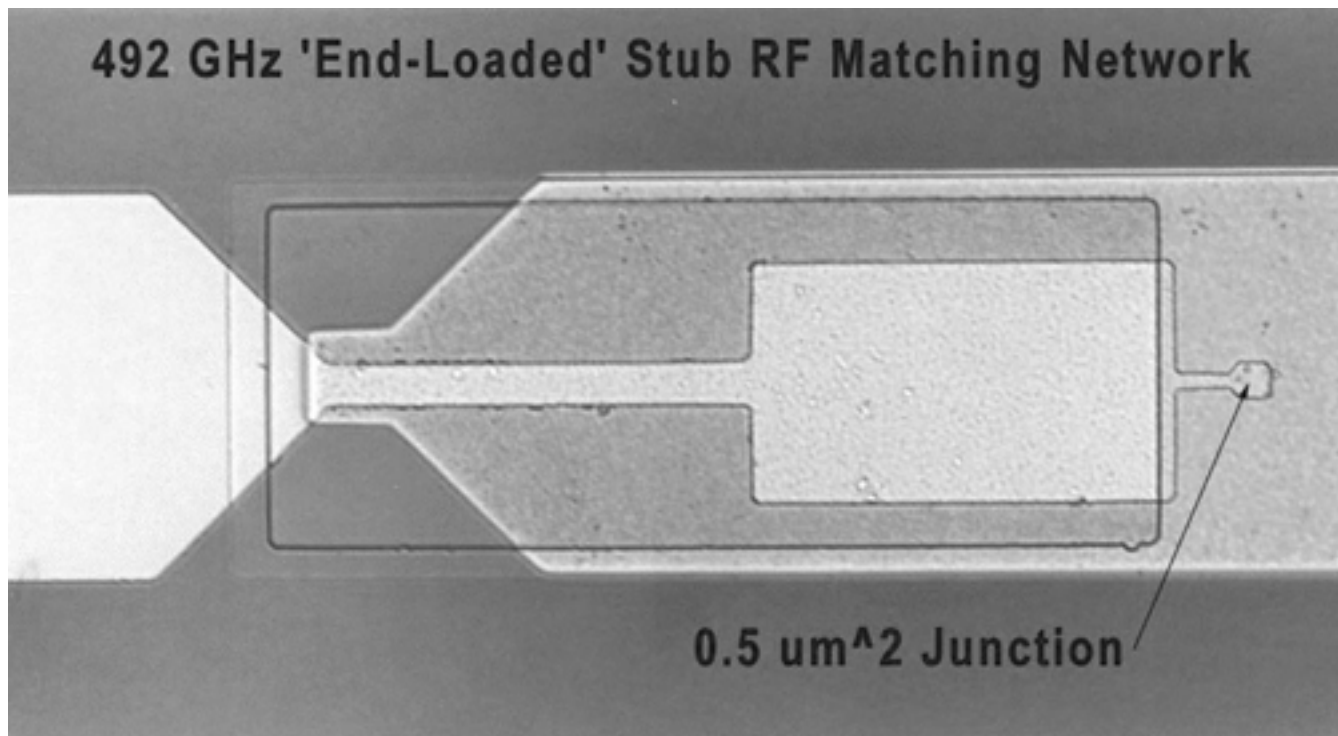

Figure 2. Physical layout of the 492 GHz SIS junction with an 'Endloaded Stub' RF matching network. The junction stub is fabricated on 150 nm thick SiO dielectric while the two section transformer is fabricated on a 450 nm thick SiO dielectric SiO ($\epsilon_r = 5.6$). The junction is deposited inside a $5\mu\text{m} \times 5\mu\text{m}$ pad for alignment purposes.

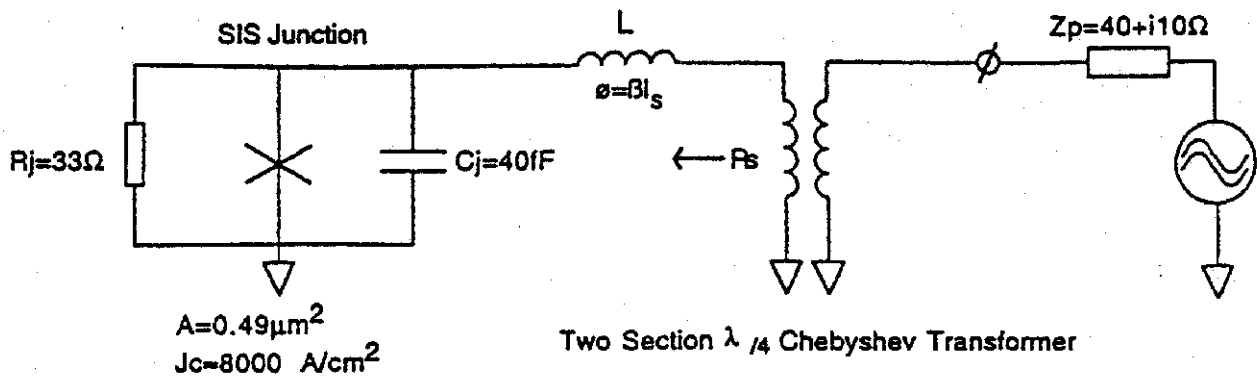

Figure 3. Equivalent electrical diagram of the RF matching network at 492 GHz. The probe impedance, $Z_p(\omega)$, is defined as the conjugate impedance seen by the bowtie antenna placed at the center of the waveguide.

For an SIS tunnel junction the geometric capacitance shunts the RF conductance of the junction. The “end-loaded” stub places a small section of transmission line in series with the junction. This results in the transformation of the complex junction admittance to the real axis of the Smith Chart (Fig. 4). To transform the very small (~1 Ohm) impedance to the desired 40 Ohm probe impedance we used a two section Chebyshev quarter wave transformer^{11,12}. Schematically this can be seen in Figure 3 and 4.

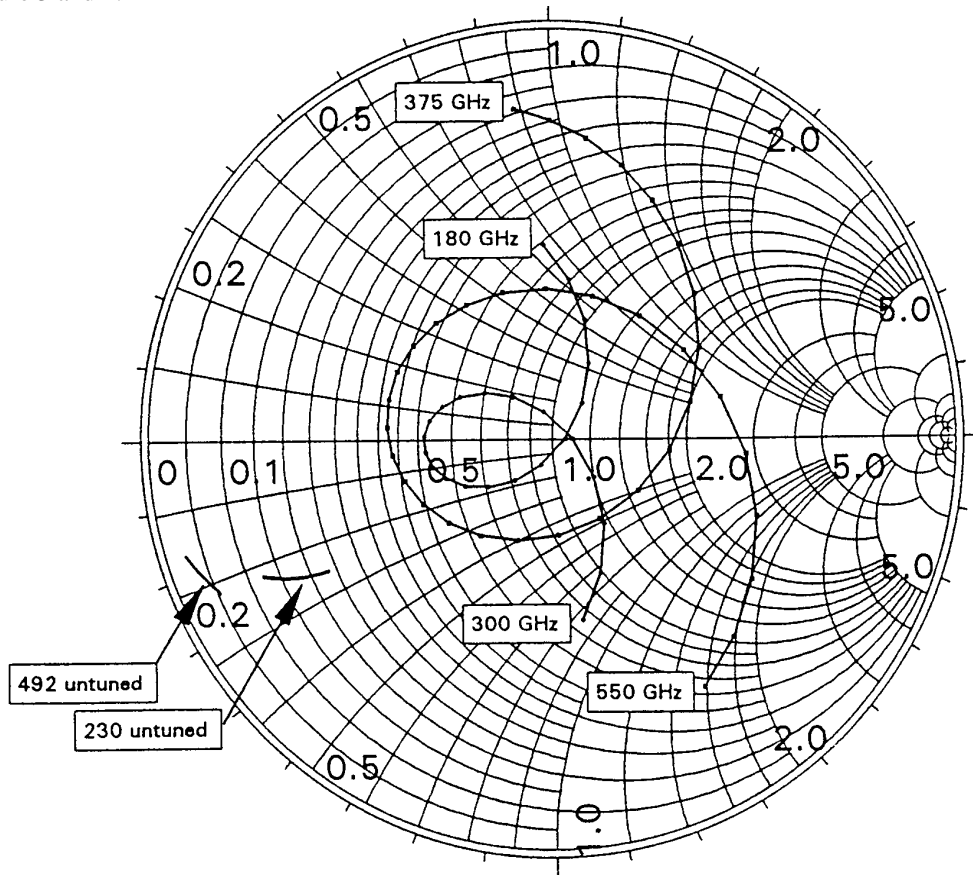

Figure 4. 230 GHz and 492 GHz tuned and untuned junction impedance plot normalized to 50 Ω. For the untuned junctions very high quality (Q) tuners are needed to tune out the probe impedance.

One of the short comings with the “end-loaded” stub RF matching network is that for frequencies above 500 GHz the low impedance section (Fig. 2) becomes physically very large indeed. In practice it is difficult to realize a very low impedance superconducting microstrip transmission line because the aspect ratio, (length/width), becomes very small. Secondly connecting the high impedance “end-loaded” stub to the low impedance transmission line results in an huge discontinuity which increases the effective electrical length of the “end-loaded” stub. And lastly, as the frequency of operation approaches that of the bandgap energy of niobium (700 GHz), the absorption loss in the superconducting material is expected to increase very rapidly^{37,38} and should be taken into account.

The “butterfly” RF matching network as shown in Figure 5 overcomes some of these difficulties. It’s operation is easily understood if one realizes that in the high frequency limit the low impedance section of the “end-loaded” stub transformer is essentially a huge parallel plate capacitance. Replacing the low impedance Chebyshev section with a set of quarter-wave radial stubs results in essentially the same electrical performance, but eliminates the large step discontinuity. This particular RF matching network has been very successfully implemented in the 620-720 GHz SIS receiver³⁹.

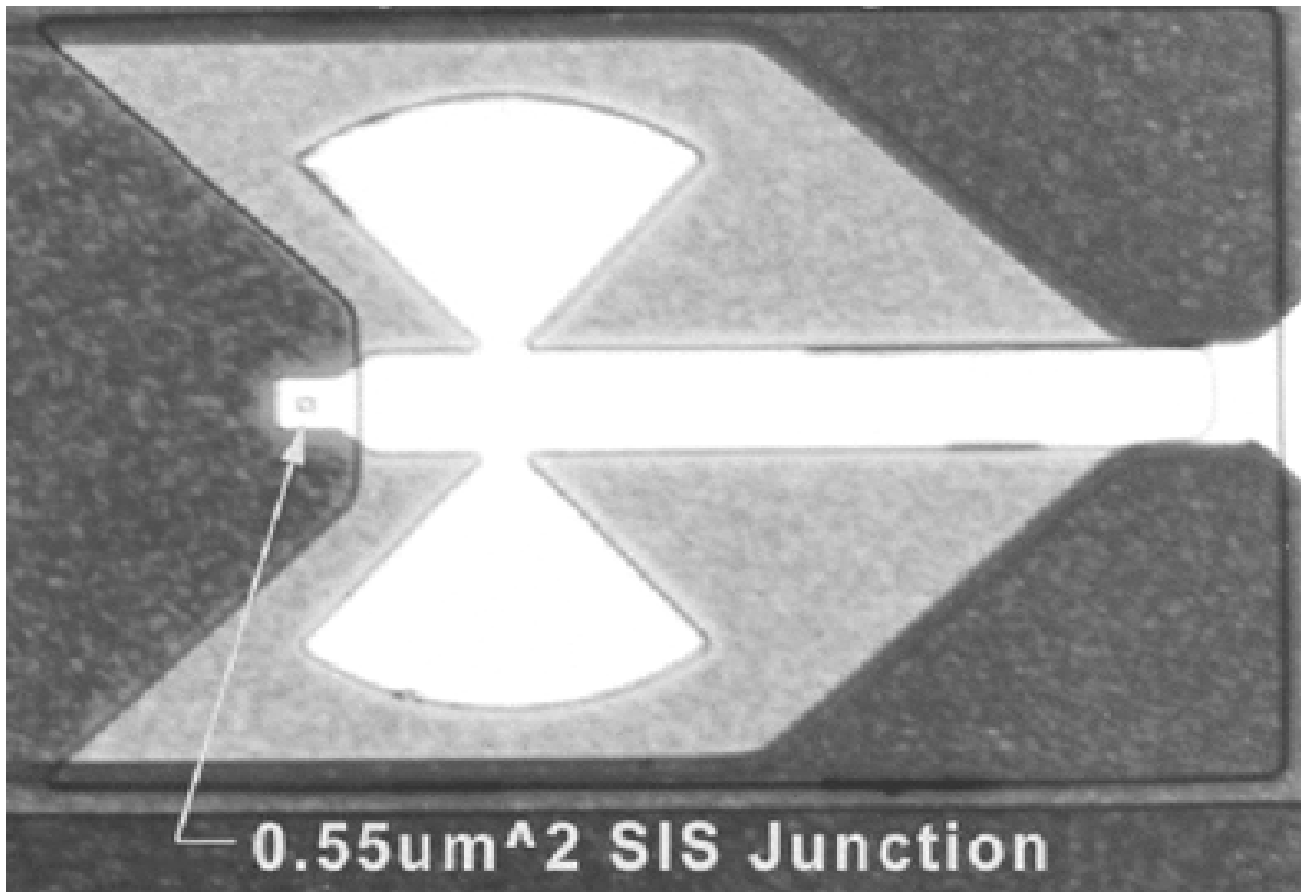

Figure 5. 1000 X photograph of the Nb/AlO_x/Nb SIS junction and “Butterfly” RF matching network. The niobium transmission line and junction wiring are deposited on 450 nm and 200 nm dielectric of SiO respectively ($\epsilon_r = 5.6$).

The frequency response of the 230, 345, 490, and 650 GHz receivers is shown in Figure 6. Unfortunately, the 665 GHz junction current density is 40% reduced from it’s design value. This has the effect that the RF matching circuit resonance is shifted in frequency to above 700 GHz, resulting in a 3 dB decrease in sensitivity at 660 GHz (¹³CO 6-5). Above 700 GHz (2Δ) the increased absorption loss in the niobium film is evident from the reduced mixer performance.

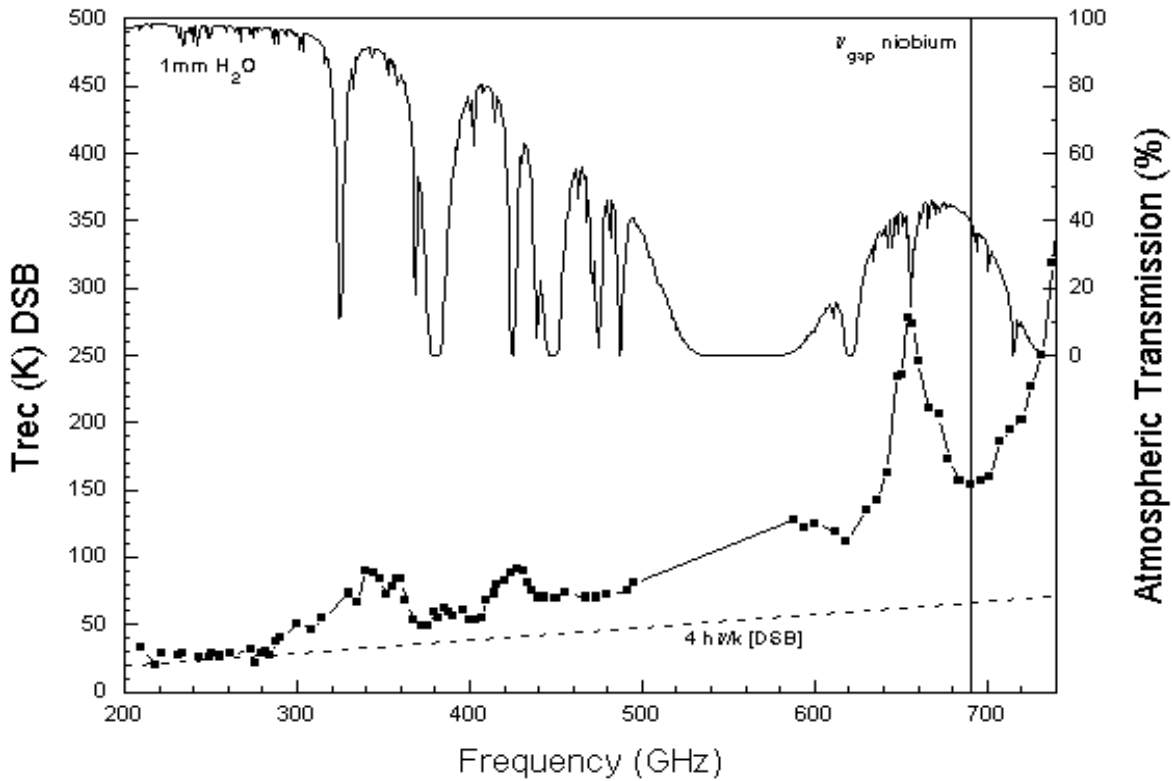

Figure 6. Frequency Response of the 230-650 GHz receivers at the CSO overlaid with the atmospheric transmission for 1 mm of perceptible H₂O.

2.3 SIS tunnel junction design above the bandgap frequency of Niobium

Traditionally, waveguide junctions have been constructed on quartz supporting substrates. To avoid RF leakage by means of surface modes down the quartz substrate, the cutoff frequency of these modes needs to be well above the operation frequency of the mixer. Unfortunately, the required thickness of the quartz and the dimensions of the substrate channel that hold the quartz junction become unmanageable small for frequencies above about 800 GHz. To avoid this problem, we explored the idea of fabricating the junction on a 1 μm Si₃N₄ membrane³¹.

At the frequencies of interest, the photons have energies larger than the superconducting energy gap of niobium, 2Δ , and are able to break Cooper pairs within the superconductor^{37,38}. This results in a large absorption loss in the niobium transmission line situated in front of the mixer, thereby seriously degrading the sensitivity of the mixer. To minimize the absorption loss (calculated to be 50% - 65% per wavelength) in the RF tuning structure above the gap, it is important to keep the RF matching circuit as simple and short as possible. Computer simulations of the “end-loaded” stub and “butterfly” RF matching networks show a niobium film absorption loss of nearly 90%, prohibiting its use³¹. For this reason we decided to use a radial stub RF matching network. It is interesting to note that this kind of matching network has a relative narrow bandwidth below the superconducting energy gap⁴⁰, where the losses are low (high Q), while above the gap the frequency response is broadened due to the dispersive loss in the niobium film.

The radial stub matching network functions by effectively placing an inductance, made out of a small section of niobium transmission line, in parallel with the junction (Fig. 7). In doing so it resonates out the large parasitic junction capacitance ($\omega R_j C_j = 8.6$ @ 850 GHz).

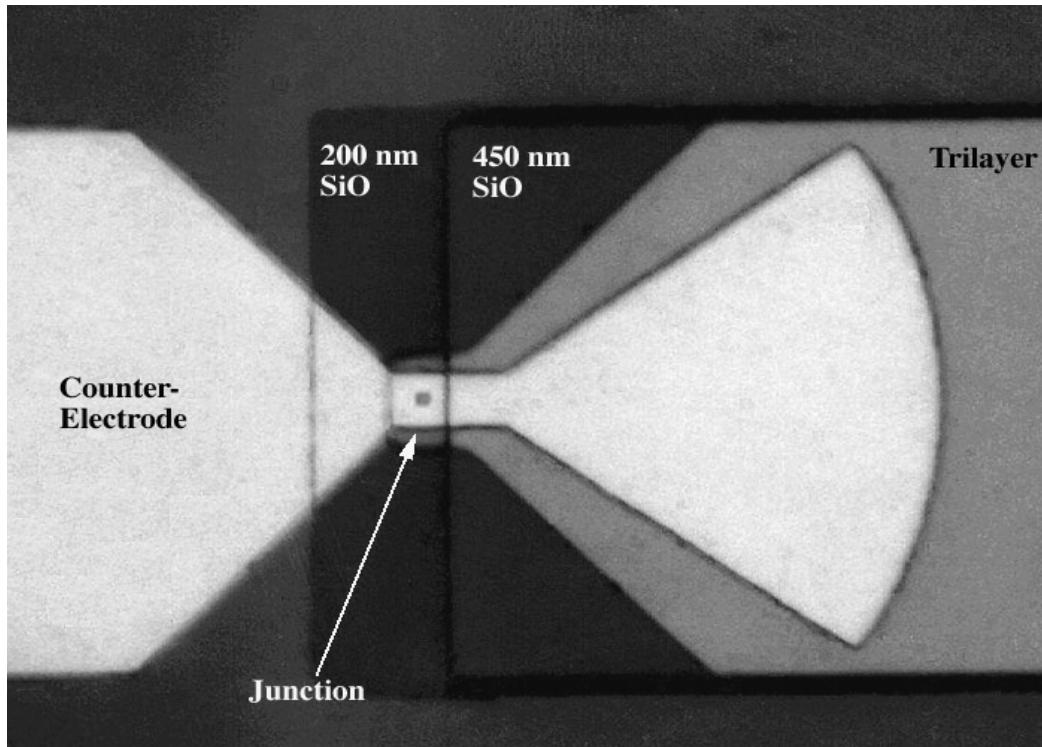

Figure 7. 1000 X photograph of the junction on silicon nitride membrane. The transmission-line length is 2.5 μm on 450-nm SiO which is terminated by a radial stub fan with a fan angle of 70 degrees. The junction size in the center of the Bowtie antenna is 0.65 μm^2 .

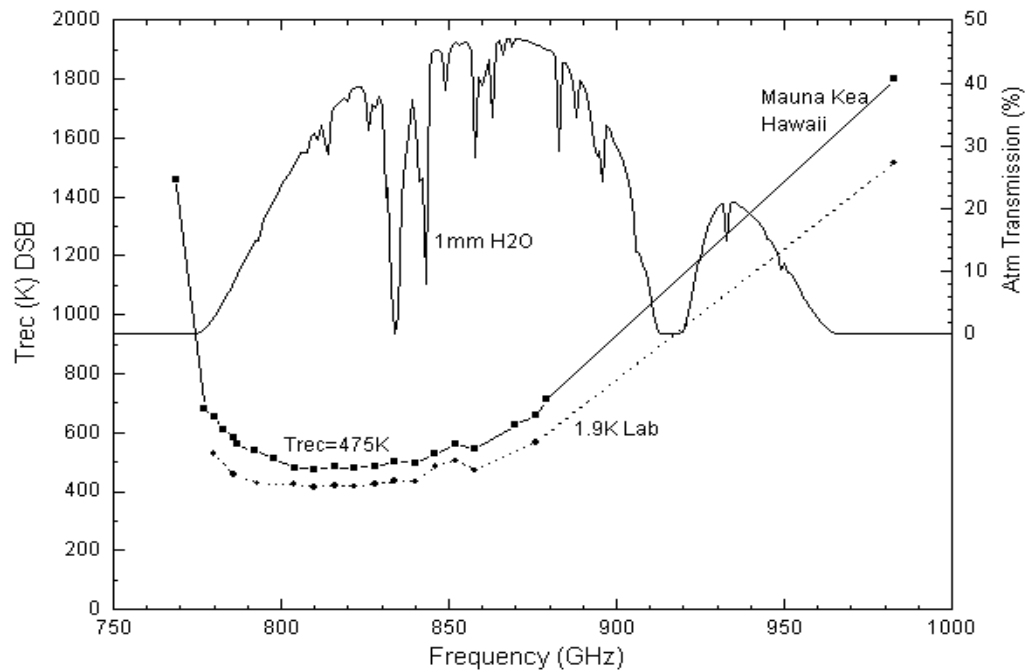

Figure 8. Frequency Response of the 850 GHz SIS receiver installed at the CSO. The receiver uses cooled (4K) optics to minimize the front end RF loss contribution. The mixer uses a Nb/ AlO_x /Nb SIS tunnel junction.

From the previous discussion it is clear that the heterodyne receiver sensitivity is severely limited by the large increase in the tuning circuit film absorption loss, which in the case of niobium occurs at 700 GHz. Recent results at 1 THz with a Quasi-optical receiver using normal-metal tuning circuits²⁸, have shown that SIS mixers can work well up to twice the gap frequency of niobium. However the performance at 1 THz is severely limited by the substantial loss in the normal metal films. To circumvent this problem, up to 1.2 THz at least, we are developing quasi-optical SIS devices with NbTiN films^{41,42}. Fourier Transform Spectroscopy (FTS) measurements of many of these devices show low loss, high Q resonances up to 1 THz. Much work in the area of NbTiN device processing and tunnel junction design remains to be done however before the promise of quantum limited performance up to 1 THz can be turned into a reality. It is envisioned however that once this new technology is mature, it will replace the current 850 GHz niobium based junction (membrane design) and open the way for a multi-pixel 800 GHz imaging array.

3. PLANNED INSTRUMENTATION UPGRADES.

3.1 Balanced 3-6 GHz low noise amplifier development

The balanced 1-2 GHz Cryogenic HEMT Low Noise Amplifier (LNA) shown in Figure 9 is currently used by all five CSO heterodyne instruments. The L-band amplifier design is based on earlier work by Padin³³ *et al*, but modified to suite the needs of the CSO.

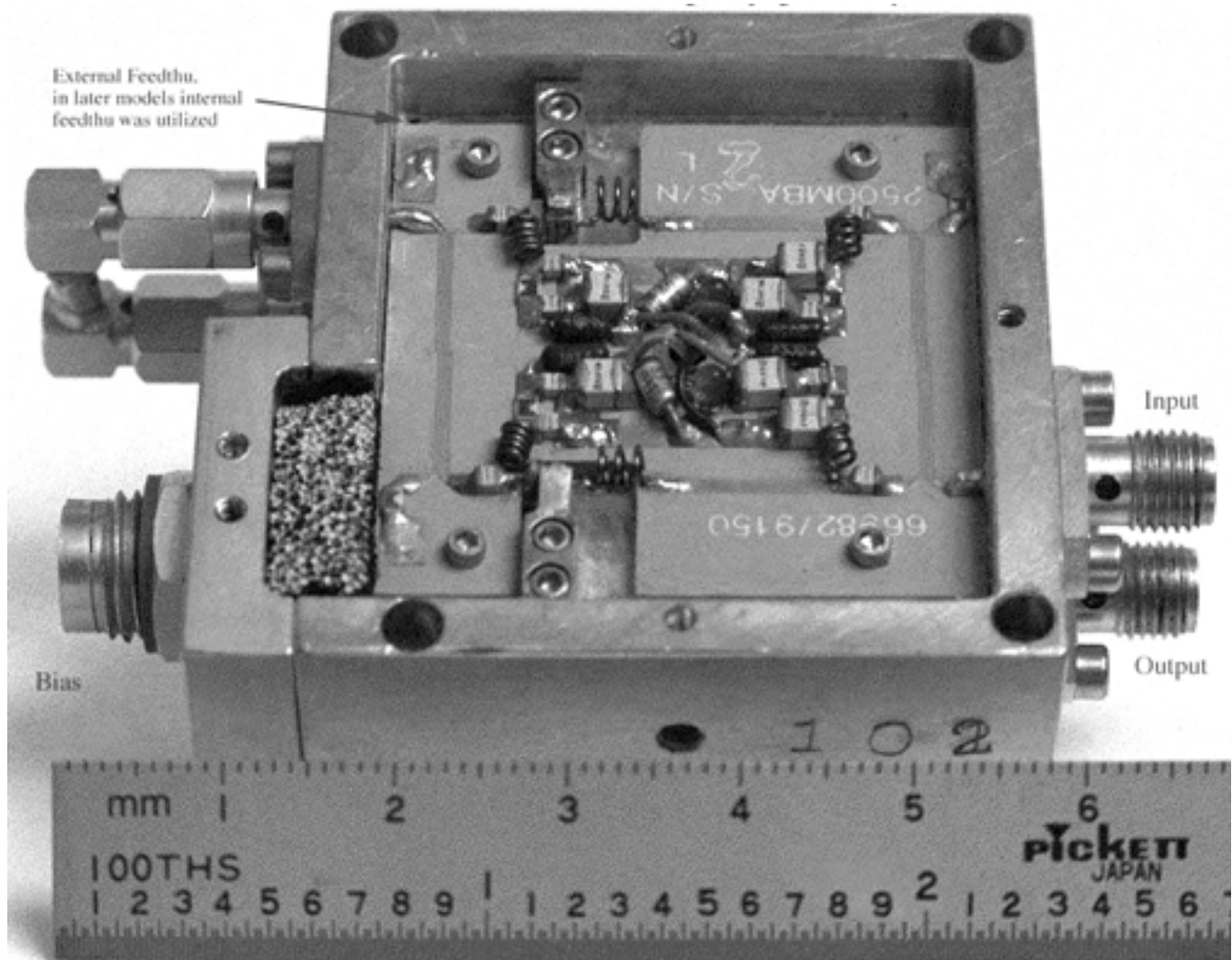

Figure 9. Balanced 1-2 GHz Cryogenic Low Noise Amplifier used in all five CSO heterodyne receivers.

Referring to Figure 9, the input of the balanced amplifier is run through a 3 dB, 90 degree Lange coupler⁴³⁻⁴⁵. Use of a Lange coupler has the advantage of isolating the input port from the isolated (S31) and direct (S21) coupled ports. The input reflection coefficient (S11) of a balanced amplifier is typically better than -15 dB, which is ideal for use with SIS mixers, whose IF impedance is a strong function of available LO power and RF match. The disadvantage of using a Lange coupler is added complexity and physical size. In the case of the CSO, the balanced amplifier serves a dual purpose. It eliminates the need for a cold (4K) isolator and provides at the same time an octave IF bandwidth, something that cannot be achieved with a cooled isolator. The noise temperature and associated gain of the L-Band amplifier is typically 4-6K and 34 dB respectively across the passband. There are two stages amplification, situated back to back in the same housing to preserve space. The 3-6 GHz balanced amplifier that is currently under development is based on the 1-2 GHz design, but will most likely be build modular for use with the beam-switching receiver discussed below. Computer simulations for a two stage amplifier (4-HEMT's) put the gain and noise temperature at 24 dB and 7-10K respectively. Alternatively, it is quite feasible to integrate High Electron Mobility Transistors (HEMT's) directly inside the mixer block⁴⁶. Though this technique has it's advantages (especially for fixed tuned and quasi-optical mixers), we do not anticipate using it at the CSO because of the added complexity to the mixer design.

3.2 CSO Mixer Upgrade and the Dual Polarization 345 GHz Beam-Switching Receiver

As part of the IF upgrade one needs to be concerned with the Instantaneous bandwidth of the receivers. In the case of the 1-2 GHz LNA, a minimum of 4 GHz of Instantaneous bandwidth is needed for true double sideband operation. In the 3-6 GHz IF bandwidth scenario however, a minimum of 12 GHz of Instantaneous bandwidth is needed, which as it turns out is a problem for the lower frequency receivers. The CSO mixers at the moment have an instantaneous bandwidth of about 2-3%, which is due to the way the microstrip probe and RF choke are situated in the waveguide.

As discussed earlier in this paper, an alternative approach to this design is the suspended-microstrip waveguide mount¹⁴⁻¹⁶, reported on by Blundell and Tong *et. al.* They have successfully used a suspended-microstrip layout in a 50% reduced height waveguide, with a fixed backshort (no E-plane tuner), to get a 33% instantaneous bandwidth. Scale mixer model studies in a variety of different waveguide heights indicate that a 25% bandwidth can be achieved with a full height suspended-microstrip waveguide mount. Given the expense and difficulty of replacing the existing CSO waveguide mixers, we have opted to change the current microstrip waveguide probe design to a suspended-stripline design. The practical consequence will be that (once the mixers are upgraded) the waveguide mixers at the observatory will for the most part be 'tunerless' unless they are used at the band-edge extremities.

The 345 GHz beam-switching receiver will be constructed with four fixed tuned, half height, waveguide mixers and a suspended-substrate RF choke design. The backshort of the four mixers will be preset with a Fourier transform spectrometer (FTS) so that all four pixels have a very similar RF bandwidth. The instrument will be polarization sensitive and be looking on source in either one of the two channel on/off positions for optimal efficiency. Beam separation on the sky will be 55''.

4. CONCLUSIONS

For the first time in it's history, the CSO offers heterodyne spectroscopy over the entire 180-950 GHz submillimeter-frequency atmospheric windows. To make this possible, five Nb/AlOx/Nb based Superconducting-Insulating-Superconducting (SIS) waveguide receivers have been successfully installed during the last several years. At the present time, the instruments have an IF passband of 1 GHz. To enhance the extra-galactic capabilities of the observatory and to allow interferometry with the upcoming Submillimeter Array (SMA) project, we are actively working towards upgrading all heterodyne instruments with a 3 GHz IF bandwidth. At the same time, a dual polarization tuner-less beam switching 345 GHz extra-galactic receiver is being constructed to help facilitate in the study of highly redshifted extra-galactic sources.

5. ACKNOWLEDGMENT

This work was supported in part under NASA Grant NAGW-107 and NSF Grant AST96-15025.

6. REFERENCES

1. J.R. Tucker and M.J. Feldman, "Quantum Detection at Millimeter Wavelength", *Rev. Mod. Phys.* 57, 1055-1113, 1985.

2. B.N. Ellison and R.E. Miller, "A Low Noise 230 GHz SIS Receiver," *Int. J. IR and MM Waves* 8, 609-625, 1987.
3. B.N. Ellison, P.L. Schaffer, W. Schaal, D. Vail, and R.E. Miller, "A 345 GHz SIS Receiver for Radio Astronomy," *Int. J. IR and MM Waves*, Vol 10, No. 8, 1989.
4. Custom Microwave, 940 Boston Ave, Longmont, CO 80501.
5. A.R. Kerr, S.-K. Pan, M.J. Feldman, and A. Davidson, "Infinite Available Gain in a 115 GHz SIS Mixer," *Physica B*, vol. 108, pp 1369-1370, Sept. 1981.
6. A. R. Kerr, S.K. Pan, M.J. Feldman, "Integrated Tuning for SIS Mixers," *Int. J. IR and MM Waves*, Vol 9, No. 2, pp. 203-212, 1988.
7. A.V. Rønnen, W.R. McGrath, P.L. Richards, and F.L. Lloyd, "Broad-band RF match to a Millimeter-Wave SIS Quasi-Particle Mixer," *IEEE Trans. Microwave Theory and Techniques*, Vol. MTT-33, No. 12, pp. 1495-1499, 1985.
8. L.R. D'addario, "An SIS Mixer for 90-120 GHz with Gain and Wide bandwidth", *Int. J. IR and MM Waves*, Vol 5, No. 11, pp. 1419-1433, 1984.
9. D.P. Woody, R.E. Miller and M.J. Wengler, "85-115 GHz Receivers for Radio Astronomy," *IEEE Trans. Microwave Theory and Techniques*, Vol. MTT-33, 1985, pp. 90-95.
10. J. W. Kooi, M. Chan, T.G. Phillips, B. Bumble, and H.G. LeDuc, "A low noise 230 GHz heterodyne receiver employing $0.25 \mu\text{m}^2$ area Nb/AlO_x/Nb tunnel junctions," *IEEE Trans. Microwaves Theory and Techniques*, Vol. 40, pp. 812-815, May 1992.
11. J. W. Kooi, M. Chan, B. Bumble, T. G. Phillips, "A low noise 345 GHz waveguide receiver employing a tuned $0.50 \mu\text{m}^2$ Nb/AlO_x/Nb tunnel junction," *Int. J. IR and MM Waves*, Vol. 15, No. 5, May 1994.
12. J. W. Kooi, M. Chan, B. Bumble, H. G. LeDuc, P.L. Schaffer, and T. G. Phillips, "230 and 492 GHz Low-Noise SIS Waveguide Receivers employing tuned Nb/AlO_x/Nb tunnel junctions," *Int. J. IR and MM Waves*, vol. 16, No. 12, pp. 2049-2068, Dec. 1995
13. C.E. Honigh, S. Haas, D. Hottgenroth, K. Jacobs, J. Stutzki, "Low-noise broadband fixed tuned wave-guide mixers at 660 and 800 GHz", *IEEE-Applied Physics*, Vol. 7(2), Part 3, pp2582-2586, June 1997.
14. R. Blundell, C.-Y E. Tong, D.C Papa, R.L. Leombruno, X. Zhang, S. Paine, J.A. Stern, H.G. LeDuc, and B. Bumble, "A wideband fixed-tuned SIS receiver for 200 GHz Operation," *IEEE Trans. Microwave Theory and Techniques*, Vol. MTT-43, April 95, pp.933-937, 1995.
15. C.-Y E. Tong, R. Blundell, S. Paine, D.C Papa, J. Kawamura, X. Zhang, J.A. Stern, and H.G. LeDuc, "Design and Characterization of a 250-350 GHz Fixed Tuned Superconductor-Insulator-Superconductor Receiver", *IEEE Trans. Microwave Theory and Techniques*, Vol. 44, No.9, September 1996, pp.1548-1556
16. R. Blundell, C.-Y E. Tong, J.W. Barrett, J. Kawamura, R.L. Leombruno, S. Paine, D.C Papa, X. Zhang, J.A. Stern, H.G. LeDuc, "A fixed tuned low noise SIS receiver for the 450 GHz frequency band", *Sixth International Symposium on Space Terahertz Technology*, Pasadena, Ca., March (1995).
17. G. de Lange, C.E. Honingh, M.M.T.M. Dierichs, H.H.A. Schaeffer, H. Kuipers, R.A. Panhuyzen, T.M. Klapwijk, H. van de Stadt, M.W.M. de Graauw, and E. Armandillo, "Quantum limited responsivity of a Nb/Al₂O₃/Nb SIS waveguide mixer at 460 GHz", *Proc. 4th Int'l Symp. Space THz Technology*, Los Angeles, pp. 41-49, 1993
18. C.E. Honingh, "A Quantum Mixer at 350 GHz based on Superconducting-Insulator-Superconducting (SIS) Junctions," *PhD Dissertation*, Groningen, The Netherlands, June 1993.
19. M.M.T.M. Dierichs, C.E. Honigh, R.E. Honingh, R.A. Panhuyzen, B.J. Feenstra, A. Skalare, J.J. Wijnbergen, H. v.d. Stadt, and Th. de Graauw, "Evaluation of integrated tuning elements with SIS devices," *IEEE Trans. Microwaves Theory and Techniques*, Vol. 41, No. 4, April 1993.
20. M. Salez, P. Febvre, W.R. McGrath, B. Bumble, H.G. LeDuc, "An SIS Waveguide Heterodyne Receiver for 600 GHz - 635 GHz," *Int. J. IR and MM Waves*, Vol 15, No. 2, Feb. 1994
21. K.F. Schuster, A.I. Harris, K.H. Gundlach, "A 691 GHz SIS Receiver for Radio Astronomy," *Int. J. IR and MM Waves*, Vol 14, No. 10, 1993.
22. M.J. Wengler, D.P. Woody, R.E. Miller, T.G. Phillips, "A Low Noise Receiver for Millimeter and Submillimeter Wavelengths", *Int. J. of IR and MM Waves*, Vol 6, pp 697-706, 1985.
23. T.H. Buettgenbach, H.G. LeDuc, P.D. Maker, T.G. Phillips, "A Fixed Tuned Broadband Matching Structure for SIS Receivers," *IEEE Trans. Applied Supercond.*, Vol. 2, No. 3, pp. 165-175, 1992
24. A. I. Harris, K.F. Schuster, R. Genzel, B. Plathner, and K.-H.Gundlach, "FANATIC: An Radiometer for Radio Astronomy from 660-695 GHz", *Int. J. IR and MM Waves*, Vol. 15, No. 9, Sept 1994.
25. P.H. Siegel and R.J. Dengler, "The Dielectric-Filled Parabola - A new Millimeter Submillimeter Wavelength Receiver Transmitter Front End", *IEEE Transactions on Antennas and propagation*, Vol. 39, No. 1, pp. 40-47, 1991.
26. J. Zmuidzinas and H.G LeDuc, "Quasi-optical slot antenna SIS mixers, *IEEE Trans. Microwaves Theory and Techniques*, vol. 40, No. 9, pp. 1797-1804, Sept. 1992.

27. J. Zmuidzinas, H.G. Leduc, J.A. Stern, and S.R. Cypher, "Two-junction tuning circuits for submillimeter SIS mixers," *IEEE Transactions on Microwave Theory and Techniques*, Vol. MTT-42, No. 4, pp 698-706, Apr 1994.
28. M. Bin, M. C. Gaidis, J. Zmuidzinas, T. G. Phillips and H. G. Leduc, "Quasi-Optical SIS mixers with Normal-Metal Tuning Structures", *IEEE Transactions on Applied Superconductivity*, Vol. 7 (2), Part 3, pp 3584-3588, Jun. 1997.
29. M. Gaidis, H. G. LeDuc, M. Bin, D. Miller, J. A. Stern and J. Zmuidzinas, "Characterization of low noise quasi-optical SIS mixers for the Submillimeter Band", *IEEE transactions on Microwave Theory and Techniques*, Vol. 44, No. 7, pp. 1130-1139, July 1996.
30. C.K. Walker, J.W. Kooi, M. Chan, H.G. Leduc, P.L. Schaffer, J.E. Carlstrom, and T.G. Phillips, "A Low-noise 492 GHz SIS waveguide receiver," *Int. J. IR and MM Waves*, Vol. 13, pp. 785-798, June 1992.
31. J.W. Kooi, J. Pety, B. Bumble, C.K. Walker, H.G. LeDuc, P.L. Schaffer, and T.G. Phillips, "A 850 GHz Waveguide Receiver employing a Niobium SIS junction fabricated on a 1- μm Si_3N_4 Membrane", *IEEE transactions on Microwave Theory and Techniques*, Vol. 46, No. 2, pp. 151-161, February 1998.
32. J.W. Kooi, C.K. Walker, H.G. LeDuc, T.R. Hunter, and T.G. Phillips, "A Low Noise 665 GHz SIS Quasi-Particle Waveguide Receiver," *Int. J. IR and MM Waves*, Vol. 15, No. 3, pp. 477-492, March 1994.
33. S. Padin, G. Ortiz. "A cooled 1-2 GHz balanced HEMT Amplifier", *IEEE transactions on Microwave Theory and Techniques*, Vol. 39, No. 7, pp. 1239-1243, July 1991.
34. A.V. Raisanen, W.R. McGrath, D.G. Crete, and P.L. Richards, "Scale Model Measurements of Embedding Impedance's for SIS Waveguide Mixers," *Int. J. IR and MM Waves*, Vol 6, No. 12, pp. 1169-1189, 1985.
35. K. Jacob's, U. Kotthaus, and B. Vowinkel, "Simulated performance and model measurements of an SIS waveguide mixer using integrated tuning structures", *Int. J. IR and MM Waves*, Vol 13, No. 1, pp. 15-26, 1992
36. T. H. Buttgenbach, T. D. Groesbeck, and B. N. Ellison, "A scale mixer model for SIS waveguide receivers", *Int. J. IR and MM Waves*, Vol 11, No. 1, pp. 1-20, 1990
37. D.C. Mattis and J. Bardeen, "Theory of the anomalous skin effect in normal and superconducting metals," *Phys. Rev.*, vol 111, pp. 412-417, 1958.
38. R. Popel, "Electromagnetic Properties of Superconductors," *Superconducting Quantum Electronics*, in V. Kose, ed., Berlin, Germany, Springer-Verlag, pp. 44-78, 1989.
39. J. W. Kooi, M. Chan, H. G. Leduc, and T. G. Phillips, "A 665 GHz Waveguide Receiver using a Tuned $0.5 \mu\text{m}^2$ Nb/ AlO_x /Nb SIS tunnel junction", *Seventh International Symposium on Space Terahertz Technology*, Charlottesville, Virginia, March 1996.
40. M. Salez, P. Febre, W.R. McGrath, B. Bumble, H.G. LeDuc, "An SIS Waveguide Heterodyne Receiver for 600 GHz-635 GHz", *Intl. J. IR and MM Waves*, vol. 15, No.2, 349-368, Feb. 1994.
41. J.W. Kooi, J.A. Stern, G. Chattopadhyah, H.G. LeDuc, B.Bumble, and J. Zmuidzinas, "Low-Loss NbTiN Films for THz SIS Mixer Tuning Circuits", *Int. J. IR and MM Waves*, Vol 19, No. 3, 1998
42. J. Zmuidzinas, J. Kooi, J. Kawamura, G. Chattopadhyah, B.Bumble, H.G. LeDuc, and J.A. Stern, "Development of SIS Mixers for 1 THz", *SPIE; International Society for Optical Engineering Proceedings*, Kona, Hawaii, 1998.
43. J. Lange, "Interdigitated Stripline Quadrature Hybrid", *IEEE transactions on Microwave Theory and Techniques*, Vol. 17, No. 12, pp. 1150-1151, December 1969.
44. W. Ou, "Design Equations on Interdigitated Directional Coupler", *IEEE transactions on Microwave Theory and Techniques*, Vol. 23, No. 2, pp. 253-255, February 1975.
45. A. Presser, "Interdigitated Microstrip Coupler Design", *IEEE transactions on Microwave Theory and Techniques*, Vol. 26, No. 10, pp. 801-805, October 1978.
46. S. Padin, D.P. Woody, J.A. Stern, H.G. LeDuc, and R. Blundell, "An Integrated SIS Mixer and HEMT Amplifier", *IEEE transactions on Microwave Theory and Techniques*, Vol. 44, No. 6, pp. 987-990, June 1996.