

## **PoleStar: An 810 GHz Array Receiver for AST/RO**

Chris Walker, C. Groppi, D. Golish, C. Kulesa, A. Hungerford, C. Drouet d'Aubigny  
SORAL, University of Arizona, 933 N. Cherry Ave. Tucson, AZ 85721 USA  
Tel: +01-520-621-3924, Email: cwalker@as.arizona.edu

K. Jacobs, U. Graf  
KOSMA, I. Physikalisches Institut Universität zu Köln Zùlpicher Str. 77 50937 Köln  
Germany

C. Martin  
Smithsonian Astrophysical Observatory, MS-78, 60 Garden St. Cambridge, MA 02138  
USA

J. Kooi  
California Institute of Technology 105-24 Caltech, 1201 East California Blvd, Pasadena  
CA 91125 USA

### **Abstract**

We have constructed a 4-channel receiver at 810 GHz for use on the Antarctic Submillimeter Telescope and Remote Observatory located at the South Pole (AST/RO). The array was assembled and tested at the Steward Observatory Radio Astronomy Lab (SORAL) and then installed on AST/RO in November-December 2000. In this paper we describe the instrument and its performance both in the lab and on the telescope.

### **Introduction**

The cold, dry conditions at the South Pole, coupled with its relatively high altitude (~10,500 ft) make it an excellent location for observations at submillimeter wavelengths. The Antarctic Submillimeter Telescope and Remote Observatory (AST/RO) with its 1.7 m aperture was designed and built to take advantage of these conditions (Stark et al 2001). Figure 1 shows a CO J=4→3 image of the giant molecular cloud NGC 6334 made with AST/RO. CO J=7→6 and [CI] spectra toward the same object are also shown. These are 'first light' data taken in the middle of the Antarctic *summer* with a dual channel, 460/810 GHz receiver system built by our team a few years ago. Much higher atmospheric transmission is routinely available in the winter. These almost ideal atmospheric conditions and the resulting observing efficiency available from the South Pole motivated us to build an 810 GHz array for use on AST/RO. Figure 2 is a photograph of the receiver 'front-end' as it appeared in the lab before deployment.

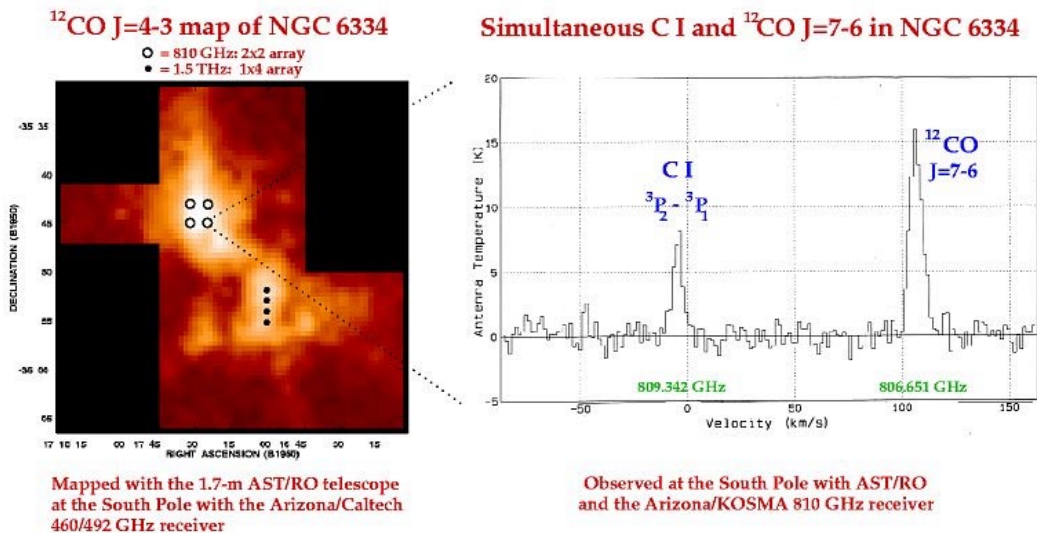

Figure 1

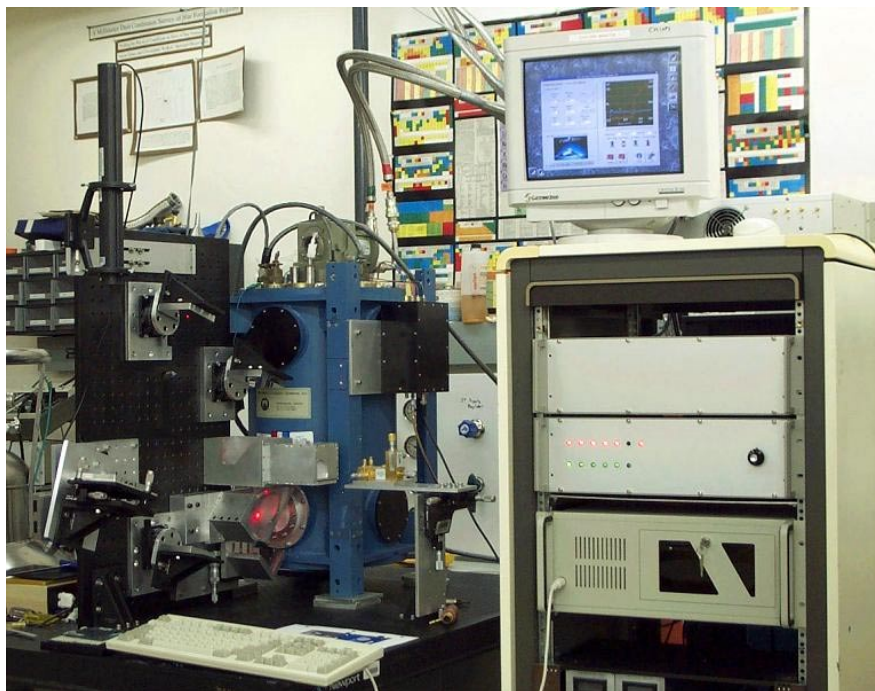

Figure 2: PoleStar frontend and control electronics during testing at SORAL.

### Pole Star Optical Design

The purpose of the optical system is to reimage AST/RO's focal plane onto a compact 2x2 array of lenses located in the array cryostat and to efficiently inject local oscillator power into each mixer. Focal plane reimaging is achieved by a pair of parabolic mirrors and two flats (Figure 3). Each AST/RO beam expands from the focal plane located ~900

mm above the receiver pallets on to the first offset parabola (P1). P1 collimates the beams and conveys them via two flats to the second parabola (P2). P2 focuses and re parallelizes the beams so that they arrive at the mixer lenses with the correct size and placement. The beam ‘footprint’ of the array on NGC 6334 is shown in Figure 1 (open circles). Each diffraction limited, half-power beam diameter is  $\sim 54''$ .

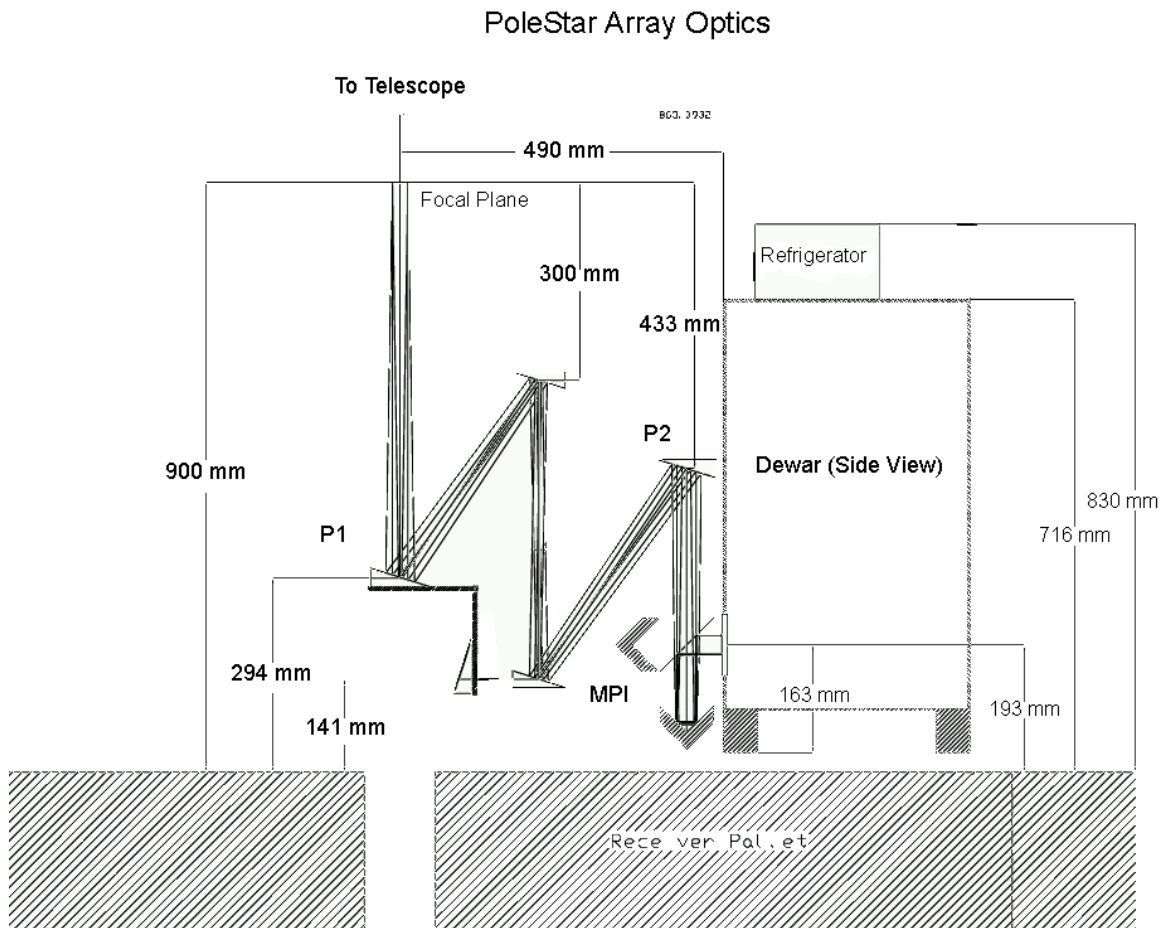

Figure 3

The local oscillator for the array is a single oscillator (J. Carlstrom) and multiplier (Erickson & Narayanan). A quasi-optical LO power divider (Figure 4) is used to split the focused,  $42 \mu\text{W}$  LO beam into 4 equal parts. The power dividing is accomplished by two, low-loss,  $\sim 50\%$  crystalline quartz beamsplitters. Each beam splitter is paired with a flat mirror to give the emerging beams the proper horizontal and vertical offsets. After including all loss mechanisms, we estimate that 18% of the incident LO power is in each LO beam at the output of the power divider. The LO polarization is orthogonal to the signal beams. The four beams are then injected into the ‘sky’ signal path by a high quality wire grid. A Martin-Puplett interferometer then rotates the LO beam polarization

to match that of the sky and directs them into the cryostat. A 2x2 array of HDPE lenses then focuses the beams into the mixer feedhorns.

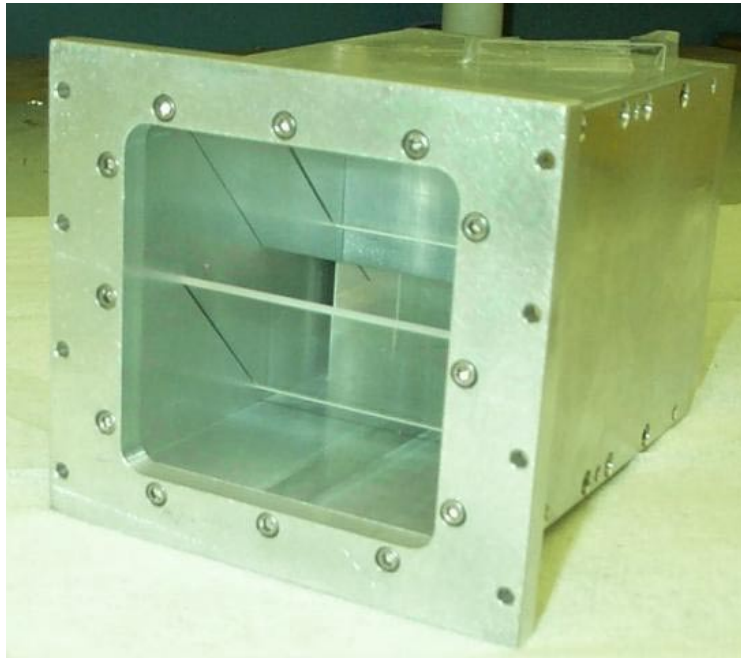

Figure 4: PoleStar's quasioptical LO power splitter.

## **Pole Star Front-End Design**

### **Cryostat**

The Pole STAR cryostat (Figure 5) was constructed by Precision Cryogenics and is based on the successful CSO hybrid design. It uses a CTI model 350 coldhead to cool the outer and inner radiation shields to  $\sim 77$  and  $\sim 12$  K, respectively and a 4 liter liquid helium can to maintain the mixers at their operating temperature. This same basic design is used for all AST/RO and CSO receivers. In the single pixel AST/RO receivers, 30.5 mm diameter, Teflon coated, crystalline quartz windows are used at 300 and 77 K. Zytex is used as the IR filter on the 12 K radiation shield. With a good vacuum, hold times of  $\sim 6$  days can be achieved. With Pole STAR, we have 4 such apertures to contend with in the same cryostat. Furthermore, Teflon coated, crystalline quartz windows are difficult to obtain and the emerging beams from our close-packed lens array makes it impossible to fabricate 4 independent vacuum windows. At 77 K, we have simply substituted an additional layer of Zytex for the 50 mil quartz windows. For the 300K vacuum window, we are using a 7.62 mm thick disk of HDPE in which 4 cylinders with the diameter of the emerging beams have been milled out to a depth of 6.65 mm (see Figure 6). The membrane thickness at the bottom of the cylinders corresponds to  $4\lambda$  at 370 microns. The machining of these windows leaves behind a thick cross member structure

which helps keep the window from collapsing under atmospheric pressure. The absorption loss through the window is estimated to be <5%. With all 4 mixers and amplifiers mounted in the cryostat, the measured hold time is ~3 days. The holdtime is much better than expected based upon the optimum performance of the single pixel receivers. This was achieved by doing away with the 'vent' tube normally used in these cryostats. In the lab we have found that without the vent tube, the fill line is LESS likely to ice up, most likely due to the increased back pressure of helium gas.

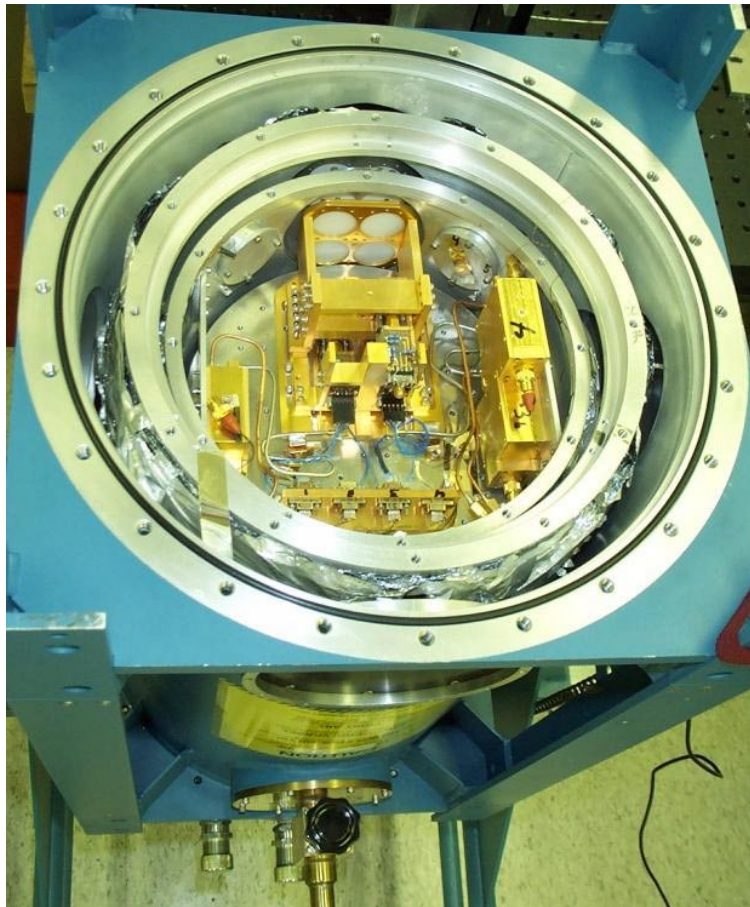

Figure 5: Layout of PoleStar array cryostat.

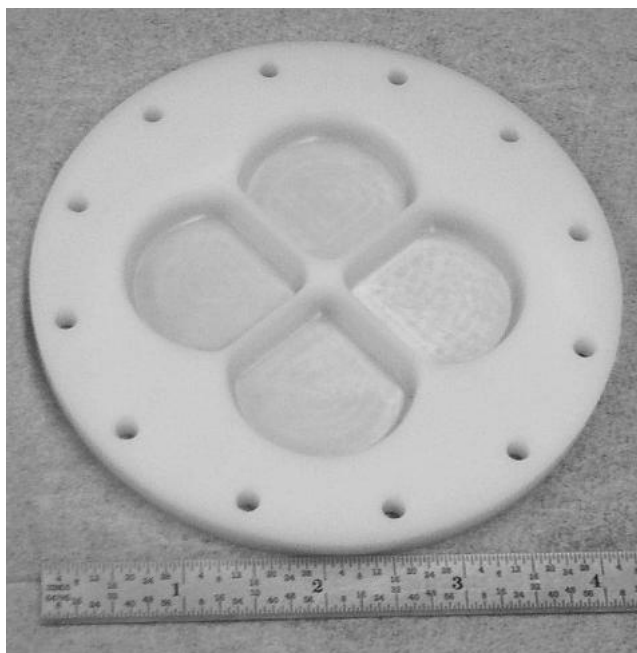

Figure 6: HDPE vacuum window for PoleStar.

### **Mixers**

The SIS mixers used in PoleStar were made by KOSMA. Each mixer uses a Potter horn with a circular to  $\frac{1}{2}$  height waveguide transition to couple radiation to a Nb SIS junction. The junctions achieve low noise ( $\sim 450 - 650\text{K}$ ) performance through the use of an on-substrate Al tuning structure and a fixed waveguide backshort. The mixers have embedded magnets to suppress the Josephson effect. A four-wire bias system is used to ensure stable operation of the mixers.

### **Pole Star IF Processing**

Figure 7 provides a global schematic of the IF processing in Pole Star. The 1.5 GHz output of each mixer is amplified  $\sim 30$  dB by a low-noise, 1-2 GHz amplifier mounted to the cryostat's 12 K radiation shield (Figure 5). The amplifiers are balanced and have a Lange coupler on their input, effectively eliminating the need for an isolator. Each signal is then amplified an additional 35 dB by room temperature Miteq amplifiers mounted on the dewar frame.

## Pole Star IF Chain

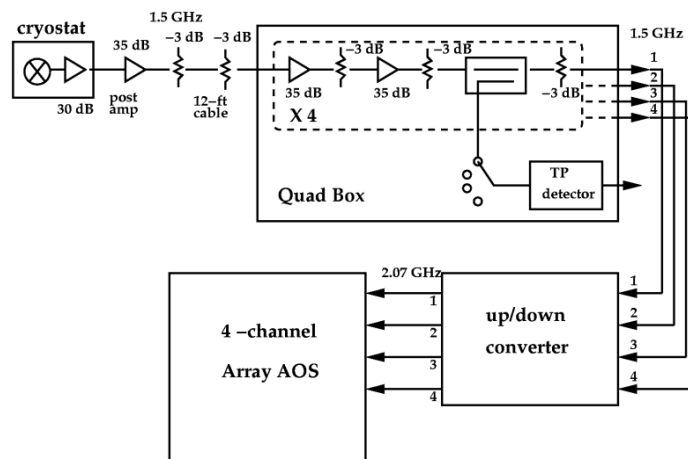

Figure 7

After passing through a 3.6m cable run the array IFs enter a 4-channel total power box. The total power box provides 60 db more amplification and contains a bandpass filter and crystal detector that permits the total power of each receiver channel to be measured either manually or under computer control. Once through the total power box, the 4 IFs enter an up/downconverter box which translates the 1.5 GHz IFs to 14.5 GHz and then down to 2.075 GHz, the center frequency required by the array Acousto-Optical Spectrometer (aAOS) (see the next section).

### Pole Star Array AOS

The Array AOS (aAOS) built by KOSMA provides four independent spectrometer channels, each with ~1 MHz of spectral resolution over a 1 GHz bandwidth. At 810 GHz, these numbers translate to 0.37 and 370 km/s respectively. It uses a single laser, a 4-channel, lithium niobate Bragg cell, and a custom CCD to achieve its performance parameters. The aAOS has been successfully tested on the IRAM 30m and CSO.

### Pole Star Bias Control

#### Hardware

The SIS junctions, the electromagnets used to suppress quantum-generated mixer noise, and the Low Noise Amplifiers (LNA's) all require noise-free, accurate electrical biasing for reliable operation. On single-pixel receivers, providing the appropriate biasing voltages and currents is handled adequately by individual boxes with manual potentiometers and LCD panels on the front. With the advent of array receivers, however, the sheer number of boxes required makes this kind of control impractical. The PoleStar

bias system uses proven circuit design used on single pixel receivers at AST/RO and the Henrich Hertz Telescope. We replace the manual potentiometers in these designs with a Xicor digital potentiometer, and package 4 channels of bias on a single Euro 96 card. These modular 4 channel cards can be plugged into a backplane in a 19" equipment rack, allowing easy extensibility to more channels. All digital communications with the bias system are done through a bi-directional optically isolated connection with the control computer. The I<sup>2</sup>C bus used for digital communications has a separate clock line. The digital lines, including the clock, are only active when changing a bias setting. The voltages and currents for the SIS junctions, magnets and amplifiers, the total power from the 4 channel total power box and the cryostat temperature information are read through a A/D card in the control computer. Signals from the bias system are multiplexed with Burr-Brown analog multiplexers, and read through a single BNC output. This design eliminates any clocks or digital signals in the bias rack except when changing to a new bias value.

A block diagram of our bias control system is shown in Figure 8. This design can support up to 16-channels with no modifications, and is extensible to over 100 channels in its current configuration using a single control computer.

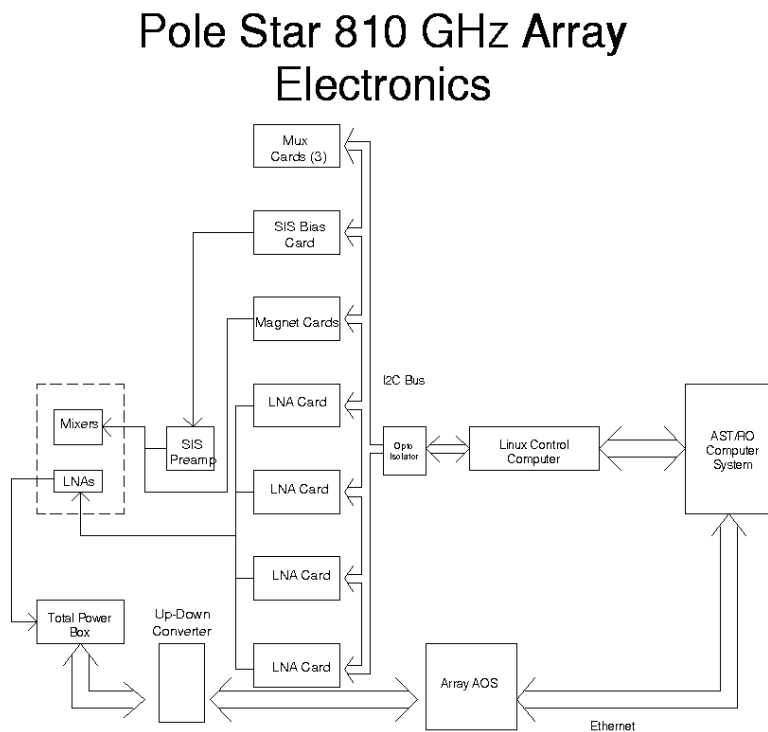

Figure 8



## Software

The philosophy of compactness and flexibility, seen in the design of the computer controlled bias electronics, carries into the software design as well. The I<sup>2</sup>C signals needed by the electronics is generated at the parallel port of an otherwise normal rack-mounted PC running the Linux operating system. The excellent documentation of system internals, tight use of system resources, remote accessibility via X-Windows, and free compilers and programming tools make Linux an excellent choice for this design. An Intelligent Instrumentation PCI-20428W multi-purpose Data Acquisition (DAQ) card is used for non-I<sup>2</sup>C control of the instrument.

The actual array software is highly modular and the source code, written in C and supplemented by Perl CGI is nearly independent of the hardware. The actual graphical user interface takes advantage of the open source, popular and highly capable GTK+ X-Windows toolkit. All bias control functions can be accessed remotely. The mixer bias control window is shown in Figure 9. The current Pole Star PC is powered by a 75 MHz AMD K5 processor, comparable to a 75 MHz Pentium, and with “only” 32 MB of RAM.

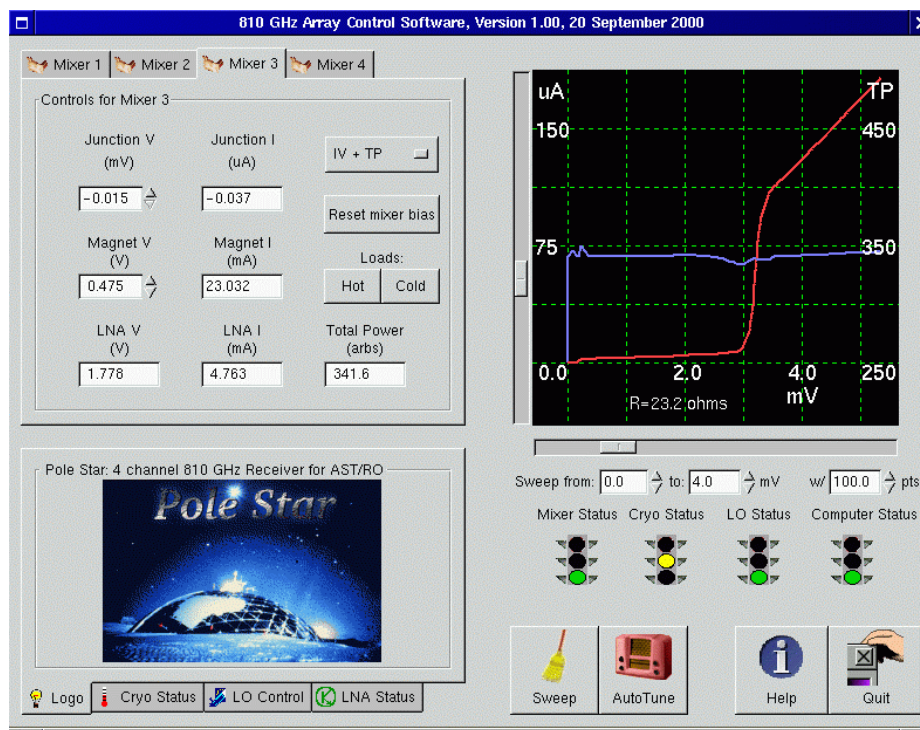

Figure 9: SIS bias control window on PoleStar

## Pole Star Performance

### Receiver Noise Measurements

Figure 10 shows the LO pumped IV curves of each of the 4 mixers together with IF power sweeps. The red curve shows the IF power output when a HOT (290K) load is placed in front of the receiver. The blue curve shows the response with a COLD (77K) load. When the system performance was optimized for each channel in the lab, a Y-factor of  $\sim 1.2$  was achieved for receivers channels 1, 2, and 3. Due to a small misalignment of the mixer's feedhorn (later corrected), a Y-factor of 1.12 was achieved on channel 4. A Y-factor of 1.2 corresponds to a receiver noise temperature of  $\sim 970\text{K}$  and includes all loss (optics, windows, Martin-Puplett, IF amp, etc.) in the system.

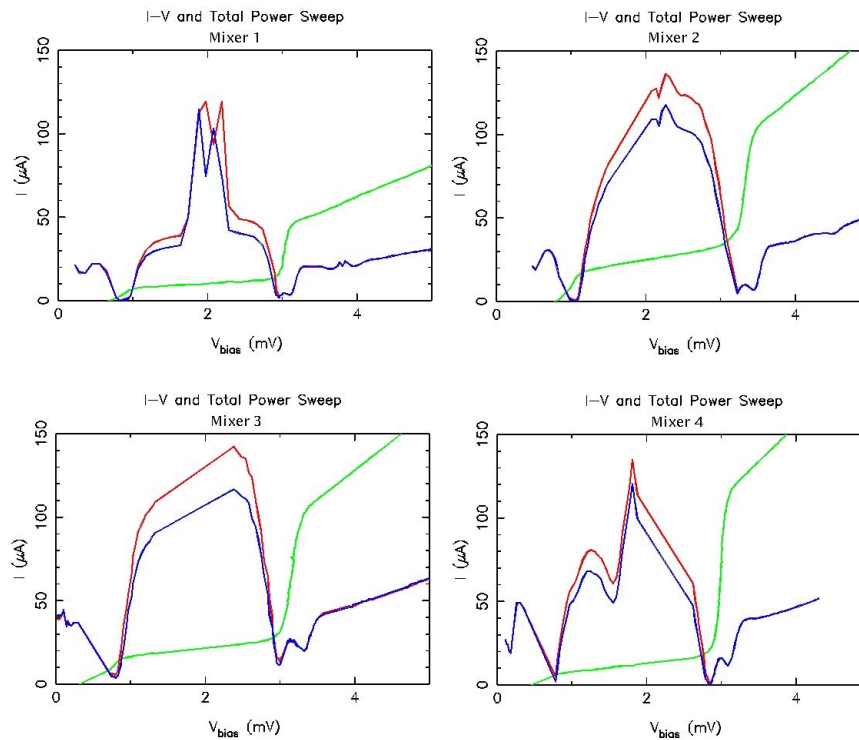

Figure 10: PoleStar receiver performance curves.

These receiver noise temperatures are about a factor of two higher than those obtained with the same mixers in a laboratory receiver system at KOSMA. In the KOSMA measurements reflective optics and a Mylar vacuum window and LO beamsplitter were used. We estimate the HDPE mixer lens and vacuum window used in Pole STAR add  $\leq 100\text{K}$  to the receiver noise temperature. The balance of the receiver noise temperature appears to come from optical loss in the Martin-Puplett LO diplexer. Due to the long path lengths and relatively large beamwaists required by the array, a loss of 3 dB in the

Martin-Puplett can occur if there is as little as  $\sim 0.5^\circ$  tilt in the entrance beam. With a single pixel system, it is often possible to adjust the relative position of the Martin-Puplett and receiver cryostat to compensate for small alignment errors. When dealing with multiple pixel systems this is much more difficult to do. Indeed, when all 4 receiver channels were optimized for simultaneous operation in Pole STAR, walk-off effects in the Martin-Puplett added an additional  $\sim 3$  dB of optical loss. These results suggest that the implementation of Martin-Puplett duplexers for large format arrays may in practice be problematic. If a narrower operational bandwidth and some loss ( $\sim 3$  dB) in LO power can be tolerated, a better approach may be to use a thin ( $\sim 3$  mm) silicon etalon (Mueller 2001) as an LO diplexer. The small path lengths through such a silicon beamsplitter would minimize the adverse effects of small optical misalignments.

Receiver stability measurements on Pole STAR were made by monitoring the IF output power of 2 of the receivers over  $\sim 1000$  sec. The IF power variation was about 1 part in 1000 over this period.

### Beam Pattern Measurements

A computer controlled antenna test range was constructed to measure the 4 Pole STAR beams. We used a liquid nitrogen load with a 10 mm aperture as the signal source. The signal was chopped and synchronously detected using a lock-in amplifier connected to the receivers' total power output. Maps of the 4-beams and their relative placement are shown in Figure 11. To within the measurement errors the beams have the right size and shape. One beam (from Mixer 3) had a small squint angle compared to the others. On warm-up, the horn on this mixer was found to be out of alignment and was readjusted.

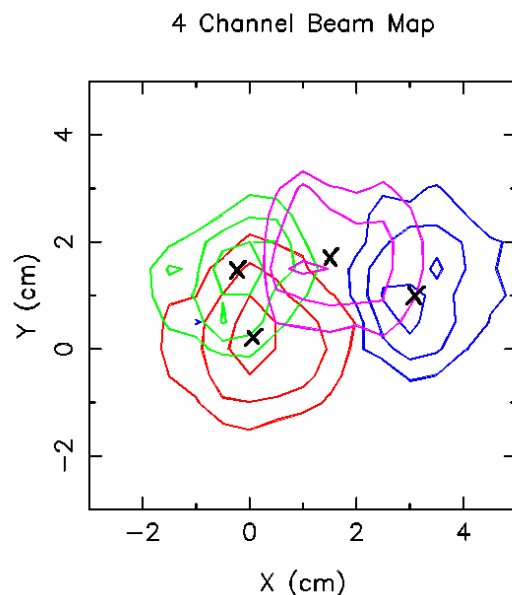

Figure 11: PoleStar beam patterns.

### First Light on AST/RO

Pole STAR was installed on AST/RO during a 3 week period from mid November to early December 2000. Figure 12 shows the First Light spectra obtained toward NGC 6334. Two CO J=7→6 and [CI] lines were observed. Pole STAR will remain at the Pole and be used for astronomical observations later this year.

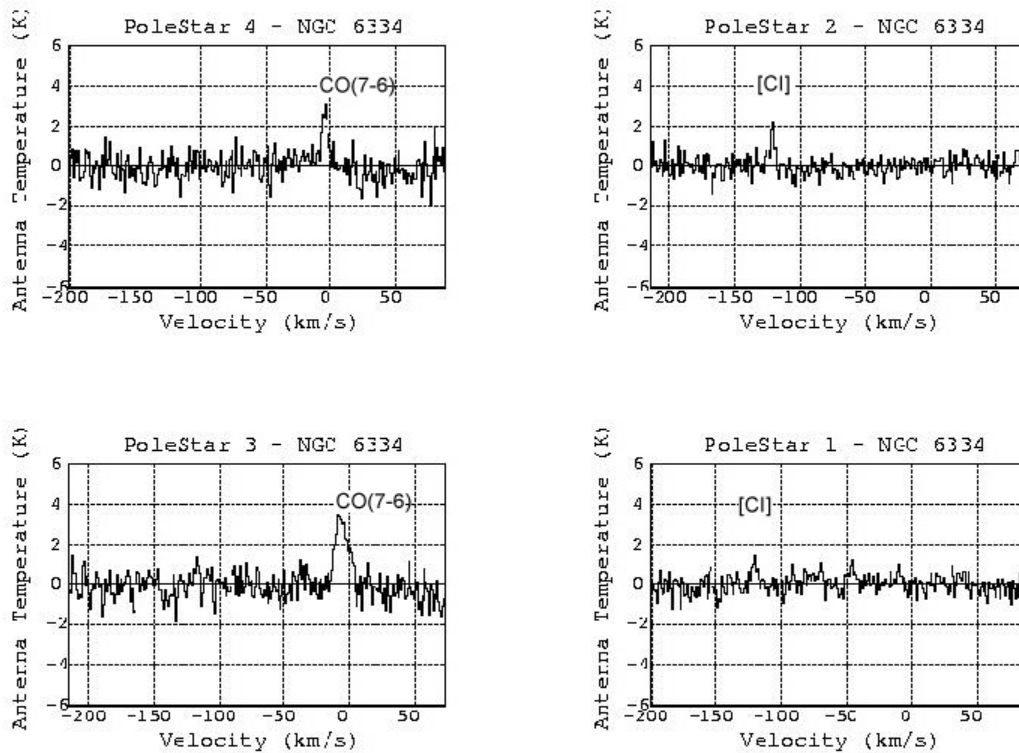

Figure 12: First light spectra taken with PoleStar at AST/RO.

### Summary

We have constructed a 2×2, 810-GHz array receiver for the AST/RO telescope. The array utilizes a common set of reimaging optics, an efficient 4-way quasi-optical LO power splitter, a solid-state LO, low noise mixers, a flexible computer controlled bias system, and an array AOS. The system is modular, permitting upgrades to be made as new technologies become available.

## References

Mueller, E., 2001, DeMaria ElectroOptics Systems, Inc., 1280 Blue Hills Ave., Bloomfield, CT 06002}.

Stark, A. et al., 2001, *The Antarctic Submillimeter Telescope and Remote Observatory (AST/RO)*, *PASP*, in press}.